

Alpha-40L RFID

■ Direct Thermal
Mobile Barcode Printers



Series Lists:
Alpha-40L(R)

User Manual

Copyright information

©2022 TSC Auto ID Technology Co., Ltd.

The copyright in this manual, the software and firmware in the printer described are owned by TSC Auto ID Technology Co., Ltd. All rights reserved.

CG Triumvirate is a trademark of Agfa Corporation. CG Triumvirate Bold Condensed font is under license from the Monotype Corporation. Windows is a registered trademark of Microsoft Corporation.

All other trademarks are the property of their respective owners. Information in this document is subject to change without notice and does not represent a commitment on the part of TSC Auto ID Technology Co. No part of this manual may be reproduced or transmitted in any form or by any means, for any purpose other than the purchaser's personal use, without the expressed written permission of TSC Auto ID Technology Co.



Table of Contents

1. Introduction	1
1.1 Product Specification	2
1.2 Battery Information.....	4
2. Operation Overview	5
2.1 Unpacking and Inspection.....	5
2.2 Printer Overview	6
2.2.1 Front View	6
2.2.2 Interior View	7
2.2.3 Rear View	8
2.3 Controls and Indicators	9
2.3.1 Keys / LCD control panel icon indication	10
3. Setup	12
3.1 Setting up the Printer	12
3.2 Charging the Smart Battery.....	13
3.2.1 Charging the Battery	14
3.2.2 Charging the Battery by 1-bay/4-bay Battery Charger (Optional)	15
3.2.3 Charging the Battery by 1-slot Docking Cradle (Optional)	16
3.2.4 Charging the Battery by 4-slot Docking Cradle (Optional)	17
3.3 Loading the Media	18

3.4 Loading the External Media	21
3.5 Installing the Belt Clip	23
3.6 Installing the IP54-rated environmental case with shoulder strap (Optional).....	24
3.7 Connecting to the Printer	26
3.7.1 Cable Communication	26
3.7.2 Wireless Communication with Bluetooth	26
3.8.3 Wireless Communication with Wi-Fi	26
3.8 Setting up the RFID	27
3.8.1 Reference Notes	27
3.8.2 RFID Media Guideline for Alpha-40L(R)	28
3.8.3 RFID Calibration	29
3.9 Changing the Media Core	31
4. LCD Menu Function	33
4.1 How to Use the LCD to Set the Printer.....	33
4.2 Main Menu Overview	34
4.3 TSPL.....	35
4.4 ZPL2.....	37
4.5 Sensor	40
4.6 Interface.....	41
4.7 File Manager.....	47
4.8 Diagnostic.....	48



4.9 Advanced.....	50
5. TSC Console	52
5.1 Start TSC Console	52
5.2 Set Wi-Fi and Add to TSC Console Interface	55
5.3 Initialize the Printer Wi-Fi Setting	58
5.4 TPH Care.....	59
5.5 Printer Function	60
5.6 Setting RFID	61
6. TroubleShooting.....	63
6.1 Common Problems	63
6.2 RFID Errors Message	65
7. RFID Setting Commands.....	68
7.1 RFID ON/OFF	68
7.2 RFID ERROR	69
7.3 RFID RETRY	70
7.4 RFID RETRYERROR ON/OFF	71
7.5 RFID POSITION	72
7.6 RFID POWER.....	73
7.7 RFID COUNTRESET	74

7.8 RFID READ/WRITE	75
8. Maintenance	81
9. Agency Compliance and Approvals	83
10. Revise History	91

1. Introduction

Thank you very much for purchasing TSC bar code printer.

The Alpha-40L(R), the first mobile RFID printer from TSC Printronix Auto ID, is user-friendly, heavy-duty and drop-resistant. The new mobile RFID printer expands our RFID lineup and propels you into the next generation of smart, RFID-enabled solutions for printing and encoding RFID labels and tags in advanced tracking and tracing applications to boost productivity.

The Alpha-40L RFID supports versatile media handling solutions including standard receipts and labels, as well as encoding RFID labels for a smarter and faster solution, when and where you need them. This innovative mobile RFID printer has an auto-calibration function that is simple and easy to use so users can start printing and encoding RFID labels without the assistance of complicated user manuals and guides.

With the Apple-certified MFi Bluetooth® 5.0 connection and 802.11 a/b/g/n/ac Wi-Fi fast roaming features, the Alpha-40L RFID not only provides reliable and seamless communication with users' devices, but also securely prints labels wherever they are needed. The data can be transferred to a central database for prompt tracking.

This document provides an easy reference for operating this printer. TSC printers include the Windows labeling software for creating your label template. For system integration, the TSPL/TSPL2 printer programming manual or SDKs can be found on TSC website at: <https://www.tscprinters.com>.

1.1 Product Specification

Item	Alpha-40L(R)
Resolution	203 dpi, 8dots/mm
Printing method	Direct thermal
Max. print speed	Up to 5 ips
Max. print width	104 mm (4.09")
Max. print length	2,794 mm (110")
Enclosure	Plastic with rubber over molded
Physical dimension (W x H x D)	160 mm x 191mm x 79 mm (6.30" x 7.52" x 3.11")
Weight (including battery)	1.025 g (2.26 lbs)
Drop specification	1.8 m (6 ft), with IP54 case can be 2.5 m (8.2 ft)
IP rating	IP54 (w/o case, paper path is excluded)
Label roll capacity	67 mm OD
Processor	32-bit RISC CPU
Memory	<ul style="list-style-type: none"> ■ Standard: 128 MB SDRAM, 128 MB Flash, microSD card reader for Flash memory expansion, up to 32 GB ■ Factory Option: 256 MB SDRAM, 512 MB Flash
Power	7.4V DC, 6,200 mAh Li-ion rechargeable smart battery
Interface	Either one selected <ul style="list-style-type: none"> ■ Type C USB 2.0 + MFi Bluetooth 5.0 + Passive NFC tag ■ Type C USB 2.0 + 802.11 a/b/g/n/ac Wi-Fi with Bluetooth 4.2 + Passive NFC tag * Type C is for communication only.
Operation button	7 buttons (Power, Feed/Enter, Menu, Navigation keys)
User interface	<ul style="list-style-type: none"> ■ 2 LED indicators (battery charging status, printer status) ■ 2.3" Color LCD display, 320 x 240 pixels
Sensors	<ul style="list-style-type: none"> ■ Reflective sensor ■ Transmissive sensor ■ Head open sensor
Real time clock	Standard
Internal font	<ul style="list-style-type: none"> ■ 8 alpha-numeric bitmap fonts ■ Monotype Imaging® true type font engine with one CG Triumvirate Bold Condensed scalable font
Bar code	<ul style="list-style-type: none"> ■ 1D bar code: Code128UCC, Code128 subsets A \ B \ C, EAN128, Interleaved 2 of 5, Interleaved 2 of 5 with

	<p>check digit, Standard 2 of 5, Industrial 2 of 5, Code39, Code39 with check digit, Code93, EAN13, EAN8, UPCA, UPCE, EAN and UPC 2 (5) digits add-on, Codabar, Postnet, MSI, MSI with check digit, PLESSEY, China post, ITF14, EAN14, Code11, TELEPEN, TELEPEN number, PLANET, Code49, Deutsche Post Identcode, Deutsche Post Leitcode, LOGMARS</p> <ul style="list-style-type: none"> ■ 2D bar code: <ul style="list-style-type: none"> CODABLOCK F mode, GS1 DataBar, GS1 DataMatrix, Maxicode, AZTEC, PDF417, QR Code, Micro PDF417, TLC39
Printer language	TSPL-EZC (EPL2, ZPL2, CPCL), or ESC-POS
Media type	Die cut, black mark, receipt, fan-fold, continuous (outside wound)
Media thickness	0.06 ~ 0.16 mm (0.002" ~ 0.06")
Media width	50.8~112mm with liner (2" ~ 4.4")
Media height	15.88 ~ 2,794 mm (0.625" ~ 110")
Media core diameter	<ul style="list-style-type: none"> ■ 25.4 mm (1"), standard ■ 19.1 mm (0.75"), with 0.75" ID adaptors, reserved ■ 38.1 mm (1.5"), with 1.5" ID adaptors, reserved
Environment condition	<ul style="list-style-type: none"> ■ Operation: -20 ~ 50°C (-4 ~ 122°F), 10~90% non-condensing ■ Storage: -30 ~ 70°C (-22 ~ 158°F), 10~90% non-condensing ■ Charging: 0 ~ 40°C (32~ 104°F), 10~90% non-condensing
Factory option	<ul style="list-style-type: none"> ■ Media sensor position (default center, right, or left side)
User option	<ul style="list-style-type: none"> ■ Type C USB 2.0 cable ■ IP54-rated environmental case with shoulder strap ■ Shoulder strap ■ Li-ion smart battery ■ 1-slot docking cradle ■ 4-slot docking cradle ■ 1-slot battery charger ■ 4-slot battery charger ■ 12-24VDC vehicle power adaptor ■ 12-60VDC vehicle power adaptor ■ 12-48VDC power source with battery eliminator ■ Vehicle mount adapter can be used with RAM® MOUNTS

1.2 Battery Information

Model	Capacity	Cycle life	Warning conditions	Charging hours	Working hours
Alpha-40L(R)	6200 mAh	500 times	<p>GOOD: Discharged count ≤ 550 or absolute battery capacity $\geq 70\%$.</p> <p>REPLACE: $550 < \text{Discharged count} \leq 600$ or $67\% \leq \text{absolute battery capacity} < 70\%$.</p> <p>UNUSABLE: $600 < \text{Discharged count}$ or absolute battery capacity $< 67\%$.</p>	4.5 ~ 6.5 hrs	<p>45 hrs</p> <ul style="list-style-type: none"> - 12.5% printing ratio - 1 label per two minutes - Bluetooth

2. Operation Overview

2.1 Unpacking and Inspection

This printer has been specially packaged to withstand damage during shipping. Please carefully inspect the packaging and printer upon receiving the bar code printer. Please retain the packaging materials in case you need to reship the printer.

Unpacking the printer, the following items are included in the carton.

- One printer unit
- One Li-ion battery
- One quick installation guide
- One auto-switching AC adapter
- One belt clip
- A pair of 0.75" media core adaptors
- A pair of 1.5" media core adaptors

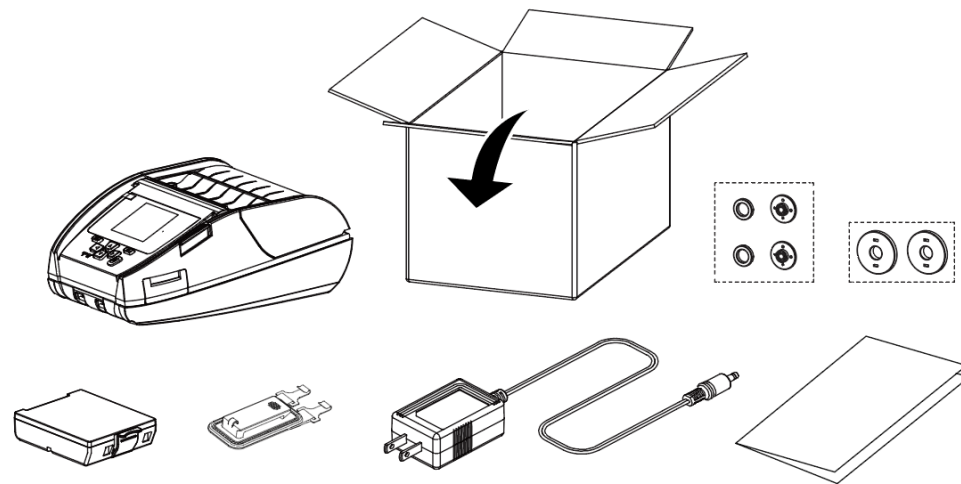

If any parts are missing, please contact the Customer Service Department of your purchased reseller or distributor.

2.2 Printer Overview

2.2.1 Front View



1. Media cover
2. NFC touch point
3. MicroSD card socket
4. Media cover release button
5. LCD screen
6. Buttons / LED indicators

2.2.2 Interior View

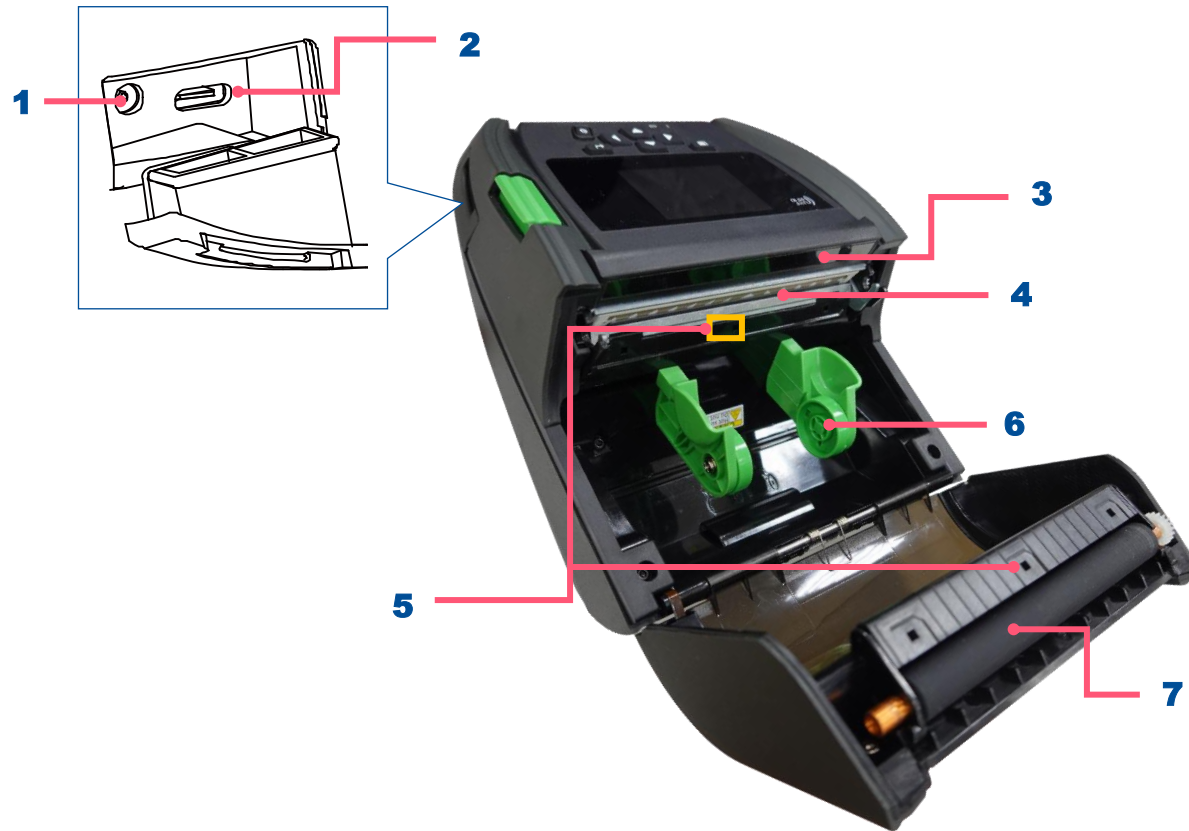

1. Power jack
2. Type C interface
3. RFID antenna
4. Printhead
5. Media sensors
6. Media holder
7. Platen roller

2.2.3 Rear View

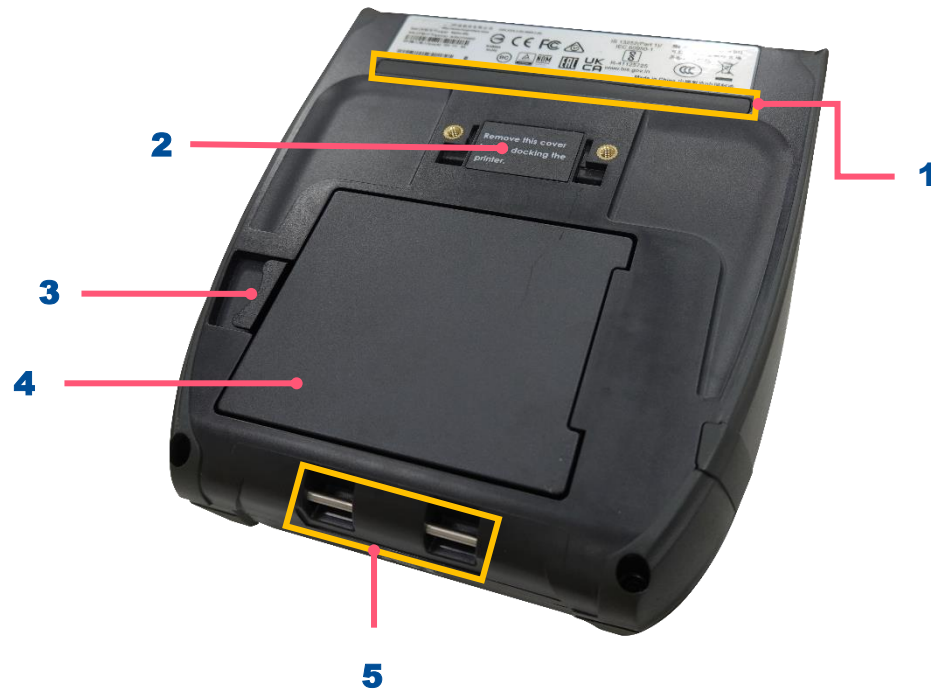





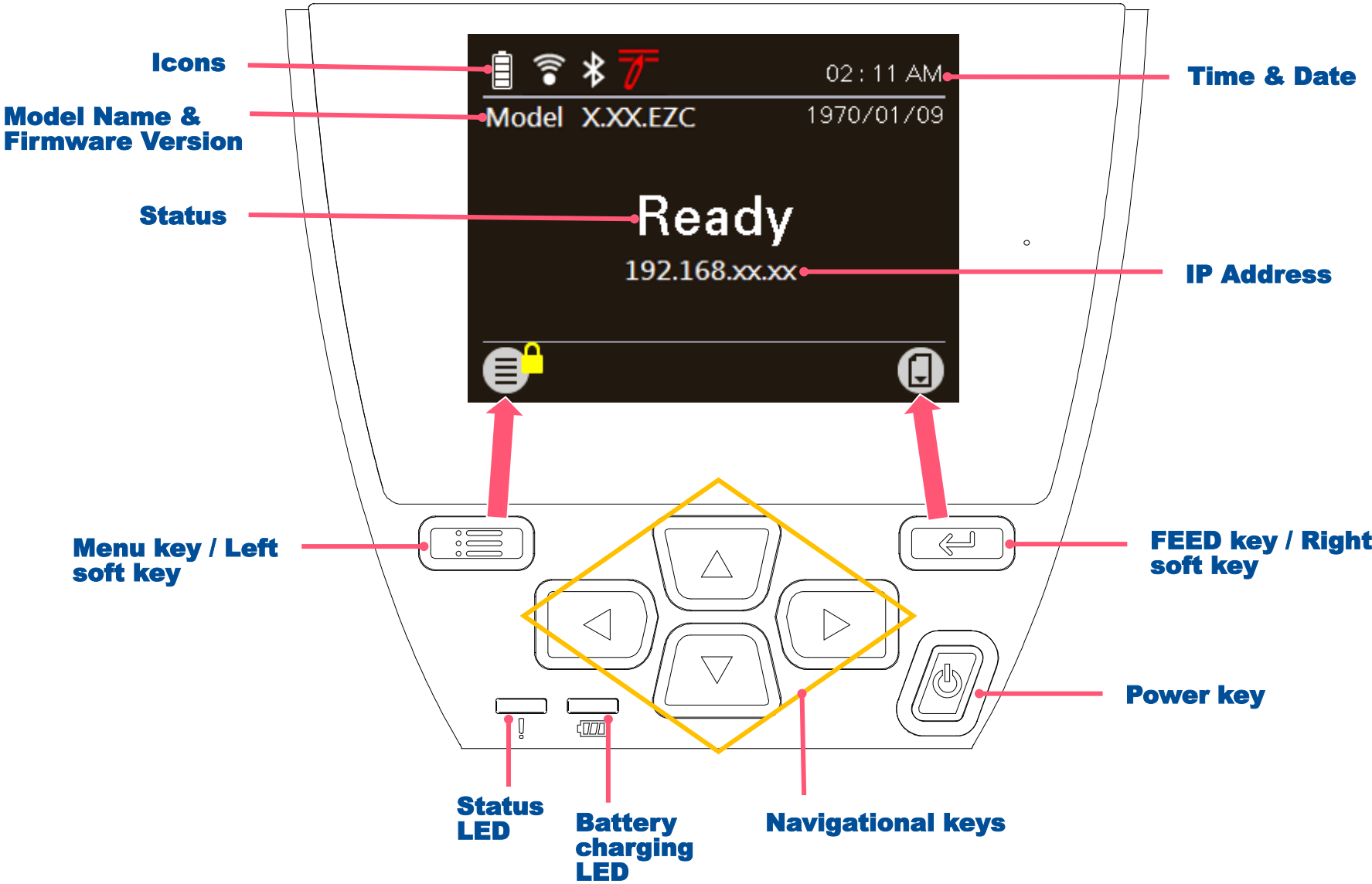

1. External label entrance chute
2. Charging position for docking cradle
3. Battery open clasp
4. Li-ion battery
5. Installation location for belt clip

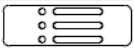
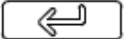





2.3 Controls and Indicators







2.3.1 Keys / LCD control panel icon indication

Keys		Function
	<ul style="list-style-type: none"> Menu key(Ready status) Left soft key (Menu status) 	<p>Enter the LCD menu list.</p> <p>The label on the left footer of the UI will explain the function for left soft key. Check the label on the footer of the UI screen. The meaning of the select keys will vary.</p>
	<ul style="list-style-type: none"> Feed key (Ready status) Pause key (Printing status) Right soft key (Menu status) 	<p>Feed one label.</p> <p>Pause the print job.</p> <p>The label on the right footer of the UI will explain the function for right soft key. Check the label on the footer of the UI screen. The meaning of the select keys will vary.</p>
	<ul style="list-style-type: none"> Power-on key 	<p>Press and hold for 2-3 seconds to turn on the printer.</p> <p>Press and hold for 2-3 seconds to turn off the printer.</p>
	<ul style="list-style-type: none"> Navigational keys 	<p>Used to select items, menu selection, and navigation in the UI.</p>



Icon	Indication
	<p>1/4 charging level: 0~25%</p> <p>2/4 charging level: 25~50%</p> <p>3/4 charging level: 50~75%</p> <p>4/4 charging level: 75~100%</p>
	<p>Wi-Fi device is ready</p>
	<p>Bluetooth device is ready</p>
	<p>Print head cleaning notice</p>

icon	Function
	<p>Enter the menu list ( the Menu is locked and a password is required.)</p>
	<p>Feed button (advance one label)</p>
	<p>Back button</p>
	<p>Enter cursor (be marked in green) located option</p>
	<p>Scroll down / up button</p>

2.3.2 Status LED indication:

	Color	Meaning
	Off	Printer is ready to use
	 (Green)	Flash: System is downloading data or printer is paused.
	 (Amber)	System is clearing data.
	 (Red)	Solid: Printer head open or errors. Flash: Printing error, such as paper empty, paper jam or memory error etc.

2.3.3 Battery charging LED indication:

	Color	Meaning
	Off	Printer is ready to use
	 (Amber)	Solid: Charging is in progress Flash: Battery temperature is too hot or too cold; Battery overvoltage; Charge timeout; Battery absent

3. Setup

3.1 Setting up the Printer



1. Open the printer's top cover Insert the right side to install the battery at the rear of the printer.



2. Push the left side of the battery.

Battery safety warning:

- DO NOT** throw the battery in fire.
- DO NOT** short circuit the contacts.
- DO NOT** disassemble the battery.
- DO NOT** throw the battery in municipal waste.



The  symbol of the crossed out wheeled bin indicates that the battery should not be placed in municipal waste.

3.2 Charging the Smart Battery

Smart Battery Charging Mode and Operation Instructions

In order to battery storage safety and increase battery storage time, the battery will be in shutdown mode for storage and shipping. The smart battery is charged for the first time, it needs to unlock this shutdown mode.

- **For charging via printer:**

No steps are required.

- **For 1-bay or 4-bay battery charger charging:**

The LED indicator on the charger will flash red when the battery is charged for the first time. Please remove the smart battery and reinstall it to unlock this shutdown mode.

Charging Temperature

The battery normal working condition is from 0°C to 40°C (32 °F to 104 °F). The device or battery charger always perform battery charging in a safe and optimum manner. At higher temperatures (e.g. approximately +40 °C (+104 °F) or charging when turning on the printers), the printer or battery charger may stop charging for a period of time to keep the battery at acceptable temperatures.

3.2.1 Charging the Battery



1. Open the interface cover.

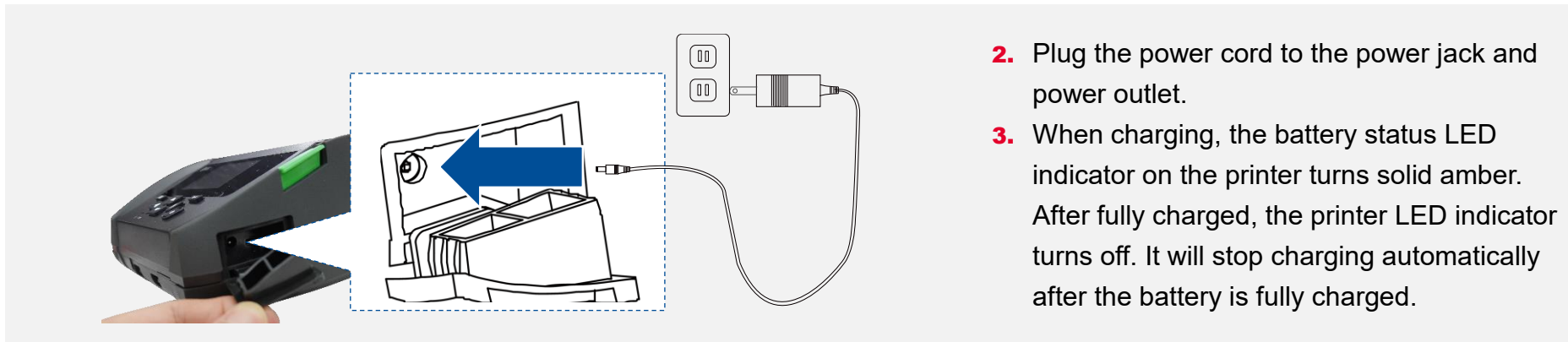

2. Plug the power cord to the power jack and power outlet.
3. When charging, the battery status LED indicator on the printer turns solid amber. After fully charged, the printer LED indicator turns off. It will stop charging automatically after the battery is fully charged.

Note:

Please switch OFF printer power prior to plug in the power cord to printer power jack.

When the battery is charging, please do not remove the battery from the printer, otherwise, please re-plug the power cord into a power outlet.

3.2.2 Charging the Battery by 1-bay/4-bay Battery Charger (Optional)

The battery

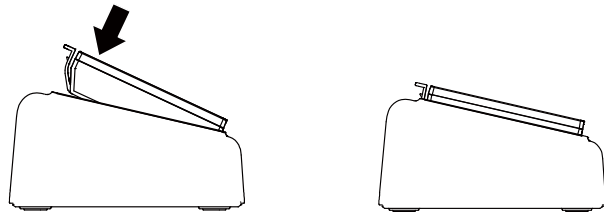

1. Plug the power adapter of the charger into a properly grounded outlet and plug the charger connector to a battery charger DC socket.
2. Push the battery down and locked by the latch as shown.

1-bay battery charger

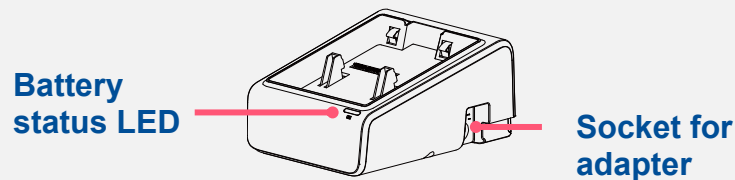

4-bay battery charger

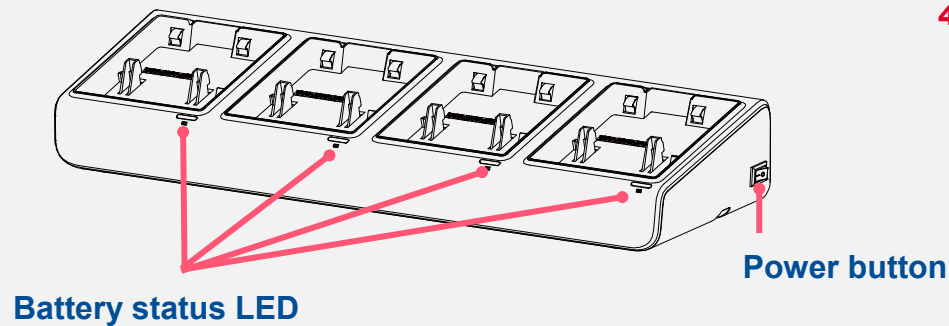

3. Plug the power cord to the power jack and plug the power cord into a properly power outlet.
4. When charging, the battery status LED indicator on the printer turns solid amber. After fully charged, the printer LED indicator turns off. It will stop charging automatically after the battery is fully charged.

3.2.3 Charging the Battery by 1-slot Docking Cradle (Optional)

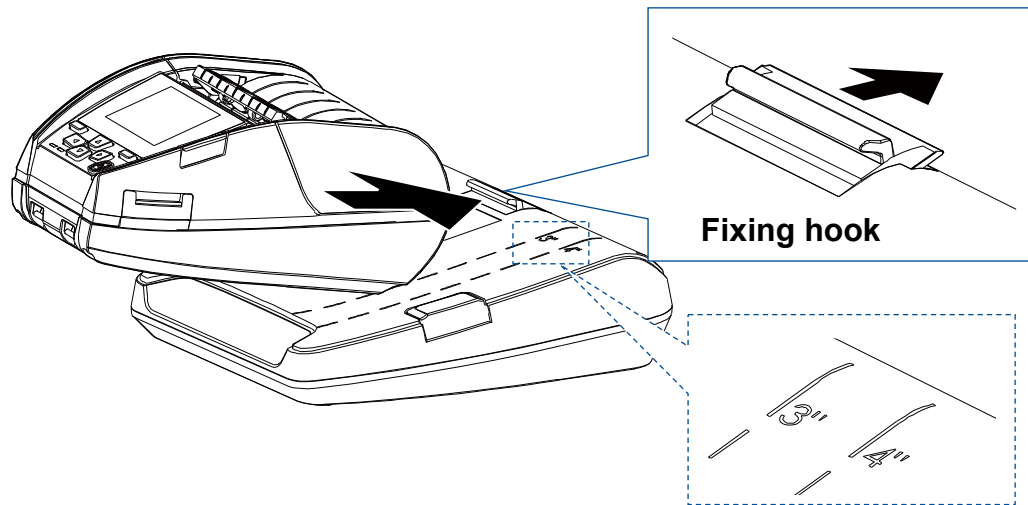

1. Plug the power adapter of the charger into a properly grounded outlet and plug the charger connector to a battery charger DC socket.
2. Push up the fixing hook with the correct angle and direction along the corresponding printer inch mark.

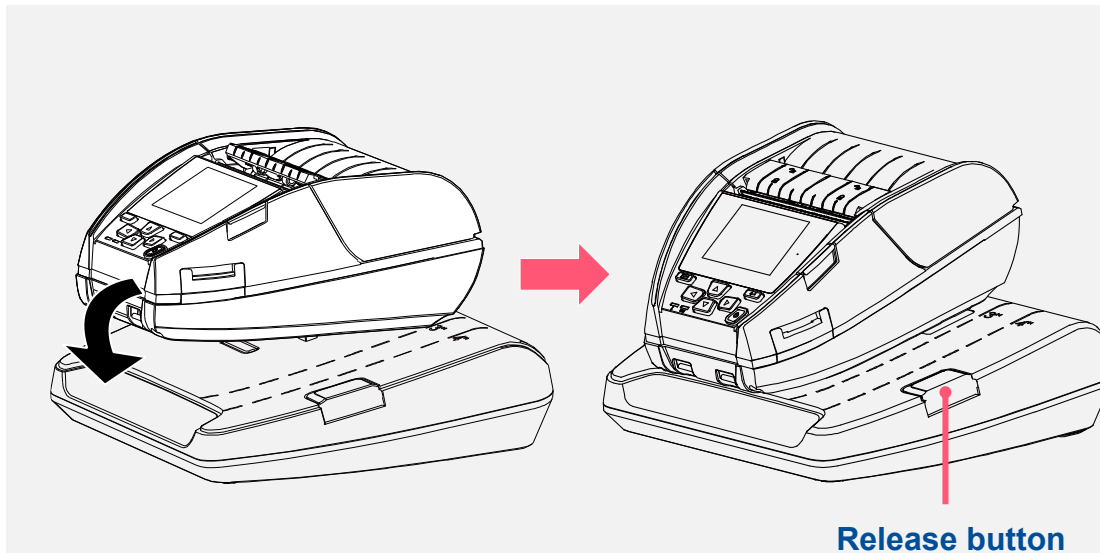

3. Push the printer down and fixed by the charger as shown, it can start charging.
4. When charging, the battery status LED indicator on the printer turns solid amber. When fully charged, the printer LED indicator turns off. It will stop charging automatically after the battery is fully charged. Press the button to release the printer.

3.2.4 Charging the Battery by 4-slot Docking Cradle (Optional)

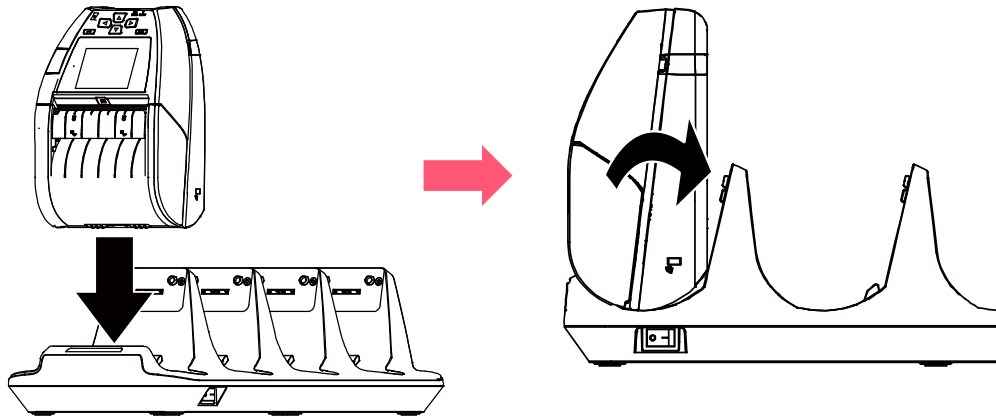

1. Plug the power adapter of the charger into a properly grounded outlet and plug the charger connector to a battery charger DC socket.
2. Install the printer onto the charger at the correct angle and direction as shown on left.

Note: To avoid damage, DO NOT install the printer at the angle shown below.

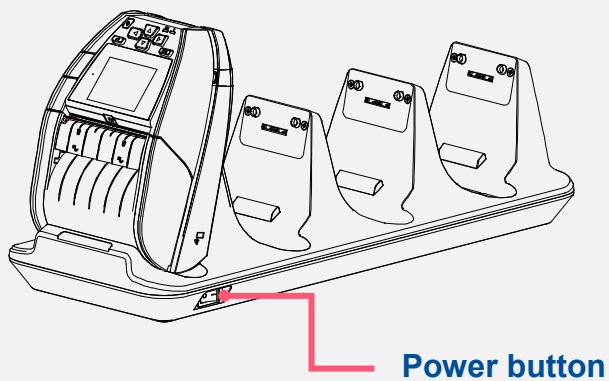
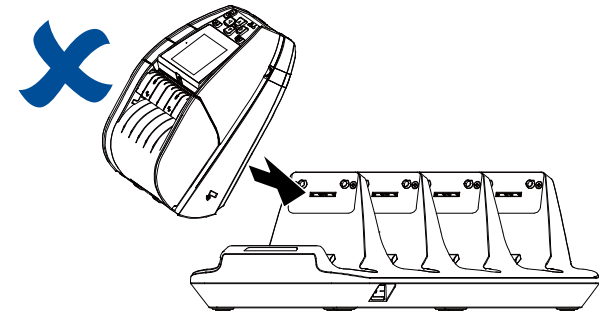

3. Turn on the power button of charger. It will start charging. (The LED on charger will turn on.)
4. When charging, the battery status LED indicator on the printer turns solid amber. When fully charged, the printer LED indicator turns off. It will stop charging automatically after the battery is fully charged.

3.3 Loading the Media

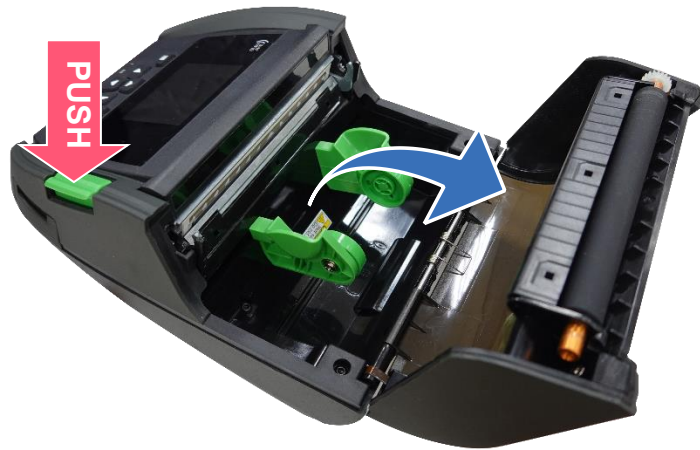

1. Open the printer media cover by pressing the media cover release button.



2. Pull the media holders apart to fit the label roll width.



3. Place the roll between the media holders and close them onto the core. Place the paper, printing side face up, and pull out enough paper over the print head.



4. Press each side of media cover to close the media cover and make sure the media cover closed correctly.

5. Press the **Menu** key to enter the LCD menu list. Go to [Sensor] → [Auto Calibration] to calibrate the media sensor.

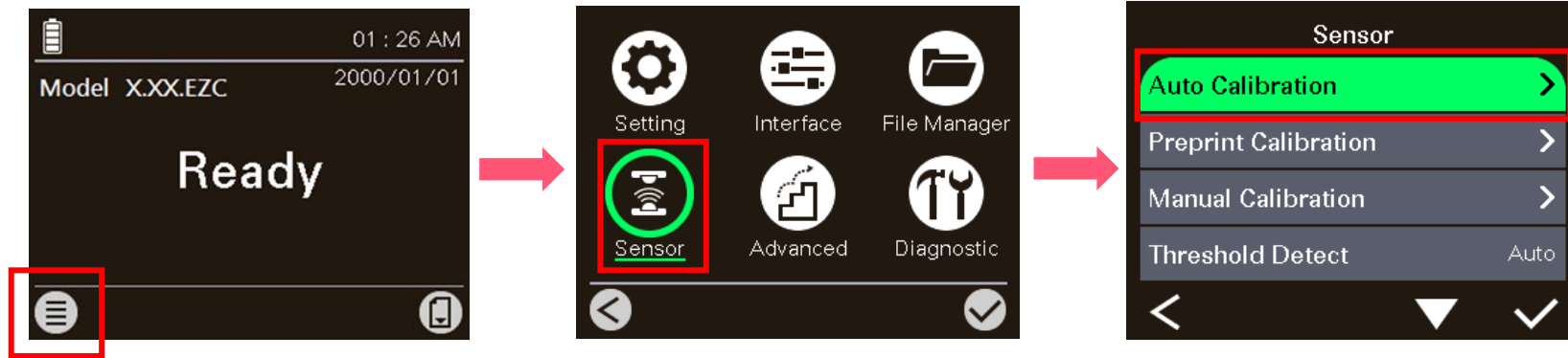

Note: Please calibrate the gap/black mark sensor when changing media.

3.4 Loading the External Media

1. Open the printer media cover.
2. Push rubber bar (inside) to remove it from printer outside.



3. Install the label roll to stuck the media holder.



3.5 Installing the Belt Clip



1. Lock the belt clip on lower of the printer.



2. Press the hook of belt clip into the bars on the lower printer as pictured. The printer can be hung on the belt.

3.6 Installing the IP54-rated environmental case with shoulder strap (Optional)

1. Zip up case cover. Place the printer in the case.

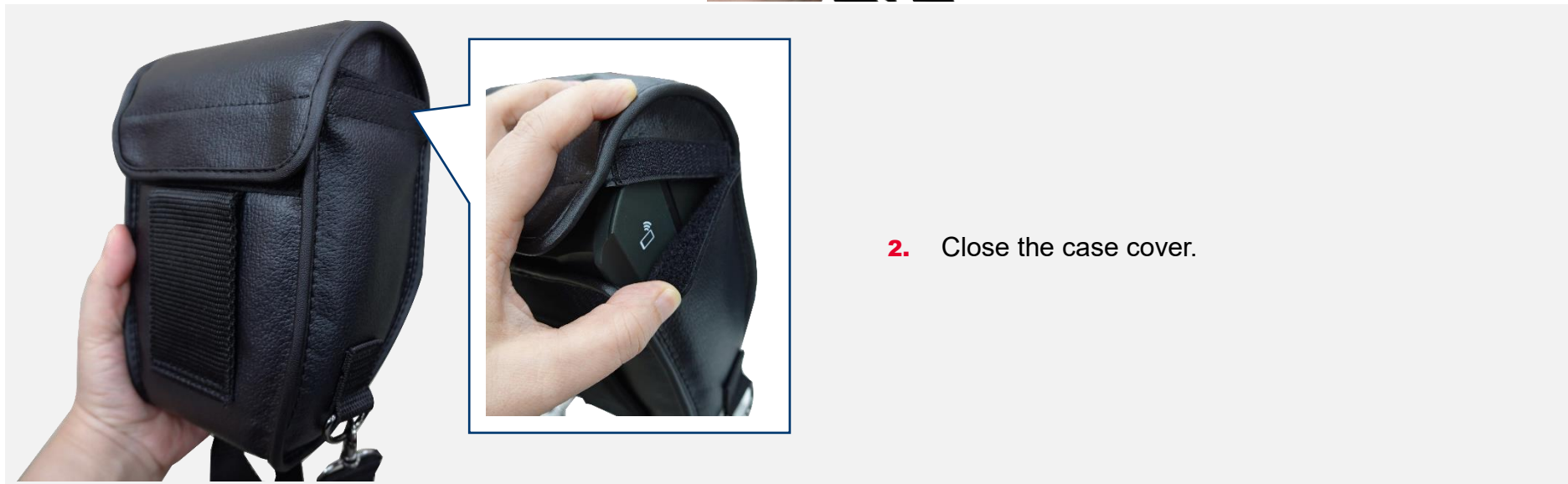

2. Close the case cover.



3. Zip up the outside cover to check. The outside cover should be opened and fixed while printing.

3.7 Connecting to the Printer

The printer must establish communication with a host terminal which sends the data to be printed.

There are 3 ways to connect for Alpha-40L series: Cable, Bluetooth, or Wireless LAN.

3.7.1 Cable Communication

1. Open the interface cover
2. Connect the printer to the computer/smart phone (host terminal) with Type C cable. (Type C to USB)

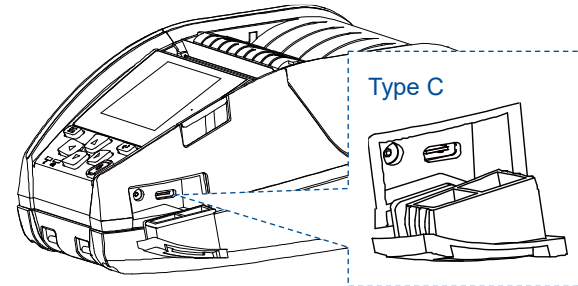

3.7.2 Wireless Communication with Bluetooth

1. Turn on the printer.
2. Enable the Bluetooth for mobile device to search (local name) and to connect the printer's Bluetooth module.
Note: Use the menu (or self-test printout) to check the Bluetooth local name.
(Menu → Interface → Bluetooth → Local Name)
3. Once the Bluetooth module is connected with the mobile device, the Bluetooth logo will be displayed on the LCD control panel.

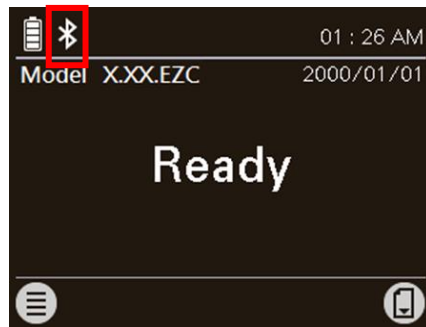

3.8.3 Wireless Communication with Wi-Fi

- Please refer to chapter 5.2 for the detailed setting.

3.8 Setting up the RFID

3.8.1 Reference Notes

Smart labels are based on an EEPROM technology that requires some time to be programmed. You may notice this minor pause between labels. This time is necessary to better ensure consistent quality and improved reliability.

When dealing with smart labels, it is possible that an occasional RFID tag may need to be written and verified more than once (retry) before being considered acceptable. In this event each retry time will be added to the inter-label pause.

Static electricity can damage the smart labels. Open the media cover of the printer and touch an unpainted metal part of the printer before you handle smart labels. This will discharge any static electricity that may have built up on your hands.

The printers are equipped with an *Auto-Calibration* feature for easy setup eliminating the need to specify exact inlay placement or RFID power settings. The calibration routine has been tested with most major inlays embedded in typical label sizes and will work with many other inlays as well.

3.8.2 RFID Media Guideline for Alpha-40L(R)

Here are a few things to consider for optimum performance. (Referring to the diagram on the right)

- Inlays should be centered across the media width with a production tolerance of less than +/- 2mm (dimension "a"). Consistent, tag-to-tag placement of the inlays is more important than how close to center the inlays are actually placed.
- Only Direct thermal media are supported. Minimum black bar size is 8 mm(w) x 2 mm(h) and position is centered.
- Maximum roll OD is 62 mm (2.44"). Media should be wound on 1", 0.75" or 1.5" ID core.
- The pitch (overall distance from inlay to inlay) is shown as dimension "P". Tags with pitch less than 1" may require the printer to back-feed during the encoding and printing process, thus slowing the throughput of the printer. The pitch should be greater than 1", if possible to avoid this condition.
- The inlay should be set back from the lead edge of the media (dimension "X") a constant distance tag to tag. The "X" distance should be more than 5 mm to prevent pre-peel.

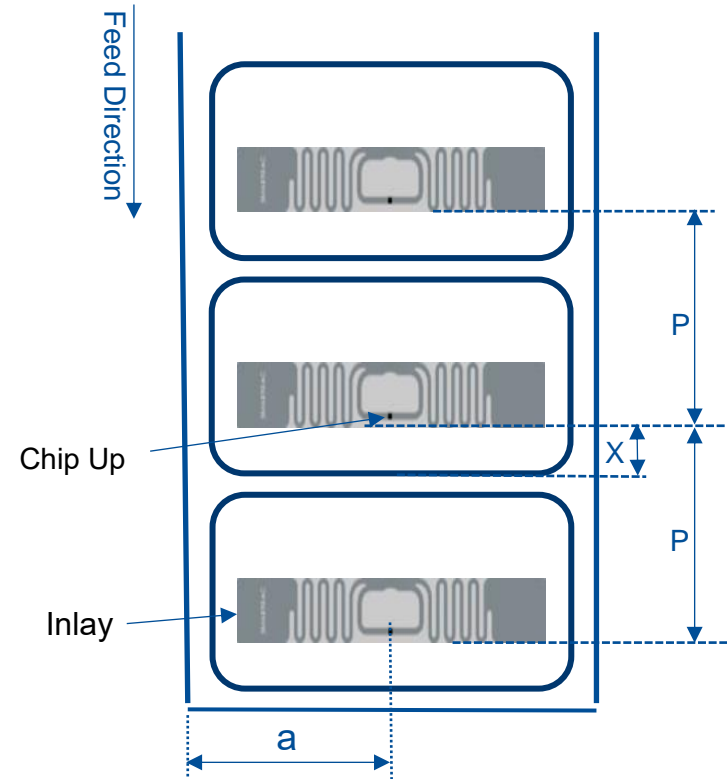

a: Center-Line
X: Lead Edge
P: Pitch

IMPORTANT: Always test RFID media on your printer before purchasing large quantities of media.

Disclaimer:

The guidelines and suggestions for developing converted RFID labels, are provided by TSC Auto ID on an "as is" basis and without warranty, expressed or implied. TSC Auto ID disclaims any implied warranty of merchantability or fitness for a particular purpose. TSC Auto ID will not be liable under any circumstances for any damages or losses related in any way to use of these guidelines, specifications or other information, including damages which may be incurred as a result of labels not working properly in a specific application. All specifications are subject to change without notice. Testing of the converted labels in the printer is strongly recommended prior to production quantities.

3.8.3 RFID Calibration

The Alpha-40L RFID printer has an RFID antenna coupler design that supports a wide variety of tag types. The antenna is affixed to the front of the printhead.

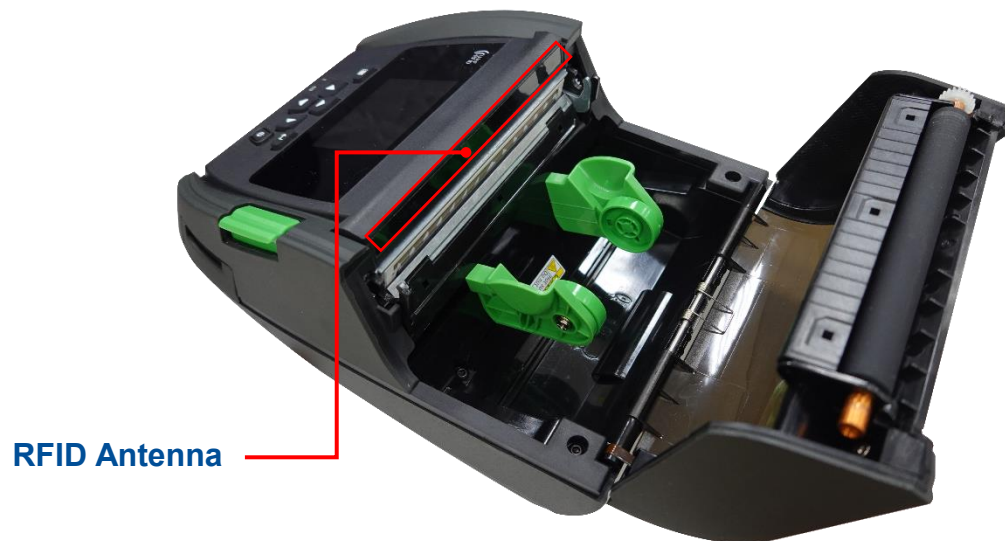

1. Refer to ch.3.3 to load the RFID media into the media spindle.

2. Press the **Menu** key to enter the LCD menu list. Go to [Sensor] → [Auto Calibration] or [Preprint Calibration] to calibrate the media sensor first, please refer to ch.4.5.

Note: For RFID with gap type media, it is recommended to use this [preprint calibration] item for sensor calibration.

3. Then enter the menu list. Go to [Interface] → [RFID] → [Tag Calibration] → [Do RFID Calibrate] to calibrate the FRID media.
4. Depending on the tag type and tag length, the calibration can take several minutes. At the end of calibration either a Green or Red window pops up. A green window signifies successful calibration and a red window means calibration has failed.
5. If calibration fails, you will see a red screen. Press the key to clear the failure notice. In some cases it may be due to an incompatibility between the tag and the reader. After calibration is complete, press the  key to continue, the RFID calibration values will be preserved. For more information, please refer to ch 4.6.

3.9 Changing the Media Core

The Alpha-40L(R) series support three size (1", 1.5" and 0.75") of media core.

Media core

Description

25.4 mm (1"), standard

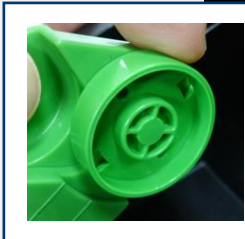

38.1 mm (1.5"), with 1.5" ID adaptors

1. Install the 1.5" ID adaptors into the 1" ID standard adaptors.

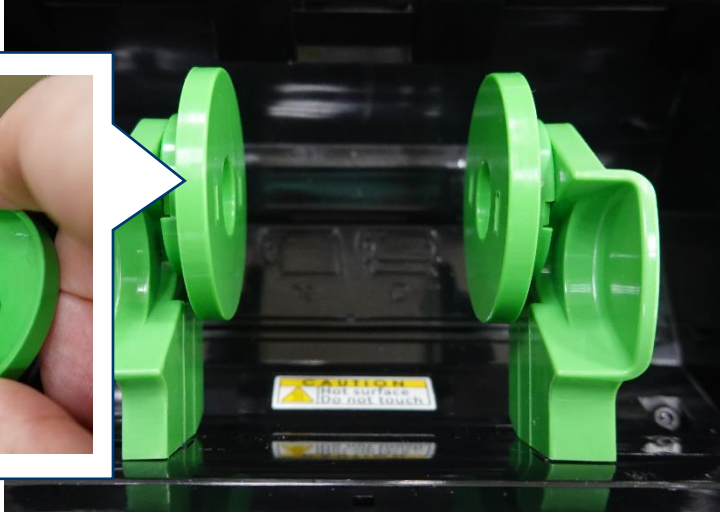
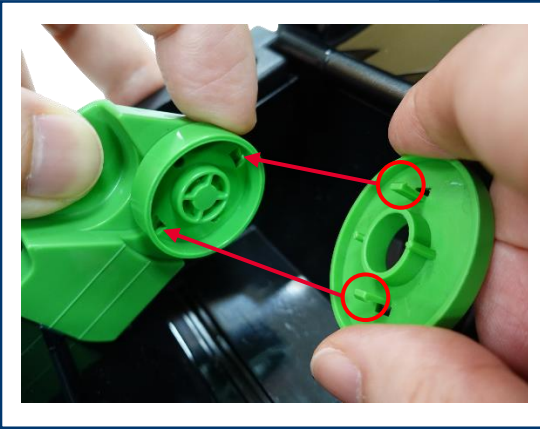

19.1 mm (0.75"), with 0.75" ID adaptors

- 1.** Remove 1" ID standard adaptors by unscrewing the screws as shown.

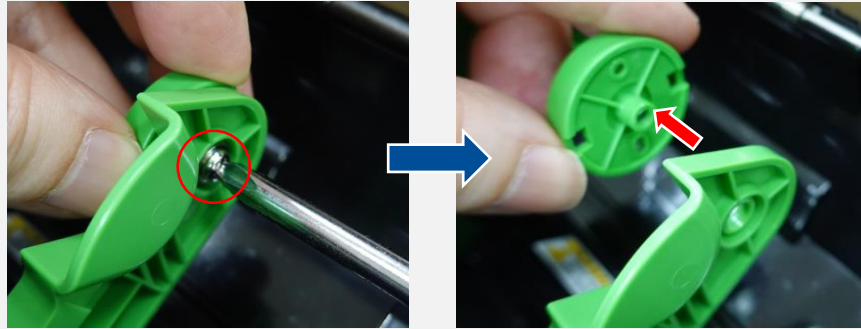

- 2.** Install the 0.75" ID rings onto the adaptor holders as shown.

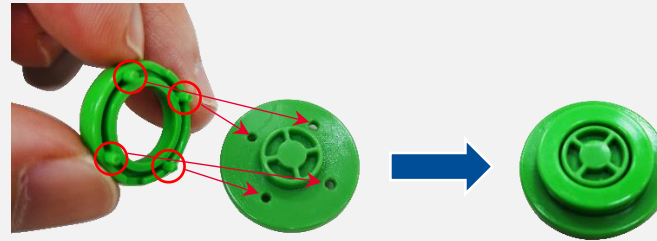

- 3.** Install the 0.75" ID adaptors into the media holder by the screws.

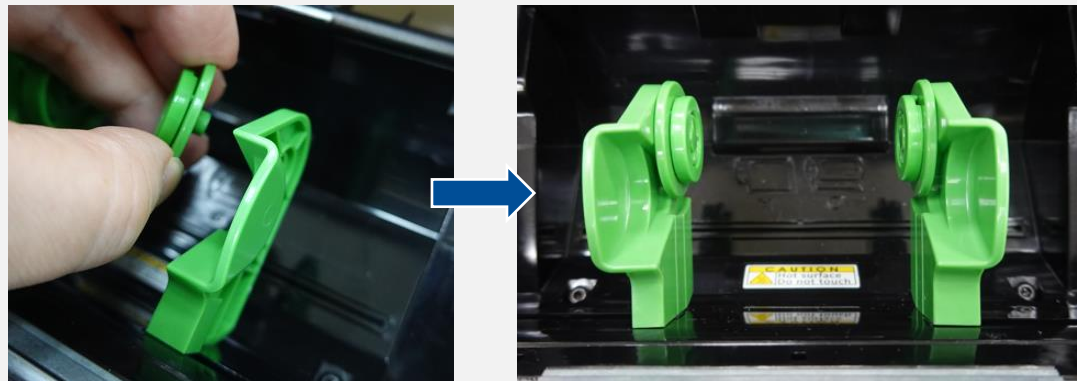

4. LCD Menu Function

The Alpha-40L(R) series offer the LCD panel to further enhance its capabilities to meet the demands of a wide range of printing solutions. This feature includes LCD control panel, 4 buttons and 2 LED display. Please press the “Menu” button to enter the setting menu.

4.1 How to Use the LCD to Set the Printer

Press the  key to enter the menu list as following shown. You can use this 4 navigational keys and soft keys to scroll, select, enter or return the menu.

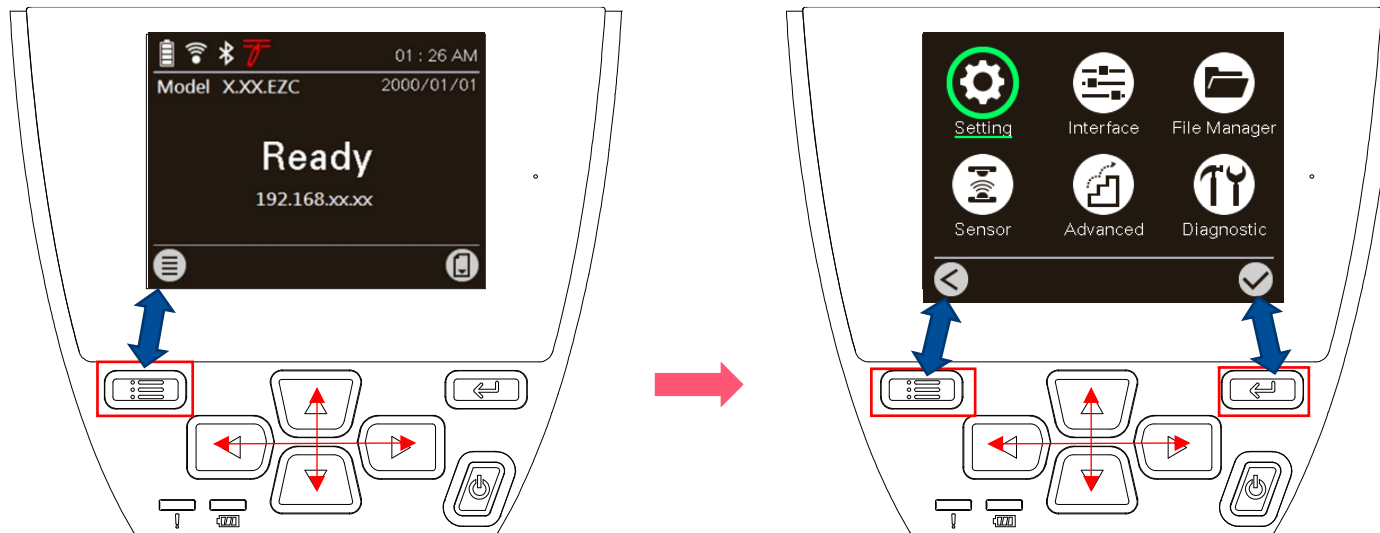

4.2 Main Menu Overview

There are 6 categories on the menu. Users can easily set the settings of the printer without connecting the computer. Please refer to following sections for more details.

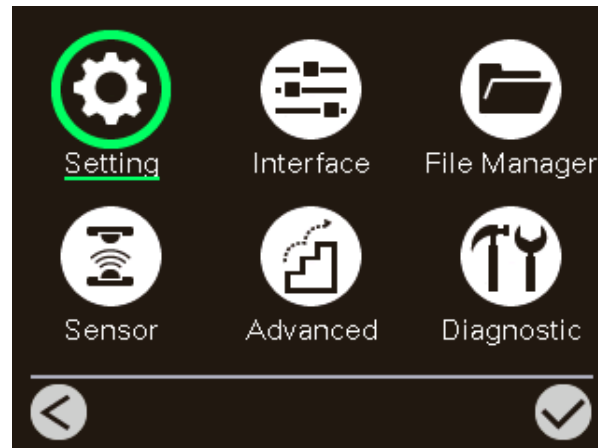

Setting : To set up the printer settings for TSPL & ZPL2.



Advanced : To set LCD, initialization, cutter type,...etc.



Sensor : To calibrate the selected media sensor.



File Manager : To check and manage printer's memory storage.

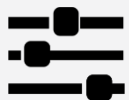

Interface : To set the printer interface settings.



Diagnostic : To check printer and help users to troubleshoot the problems.

4.3 TSPL

TSPL category can set up the printer settings for TSPL.

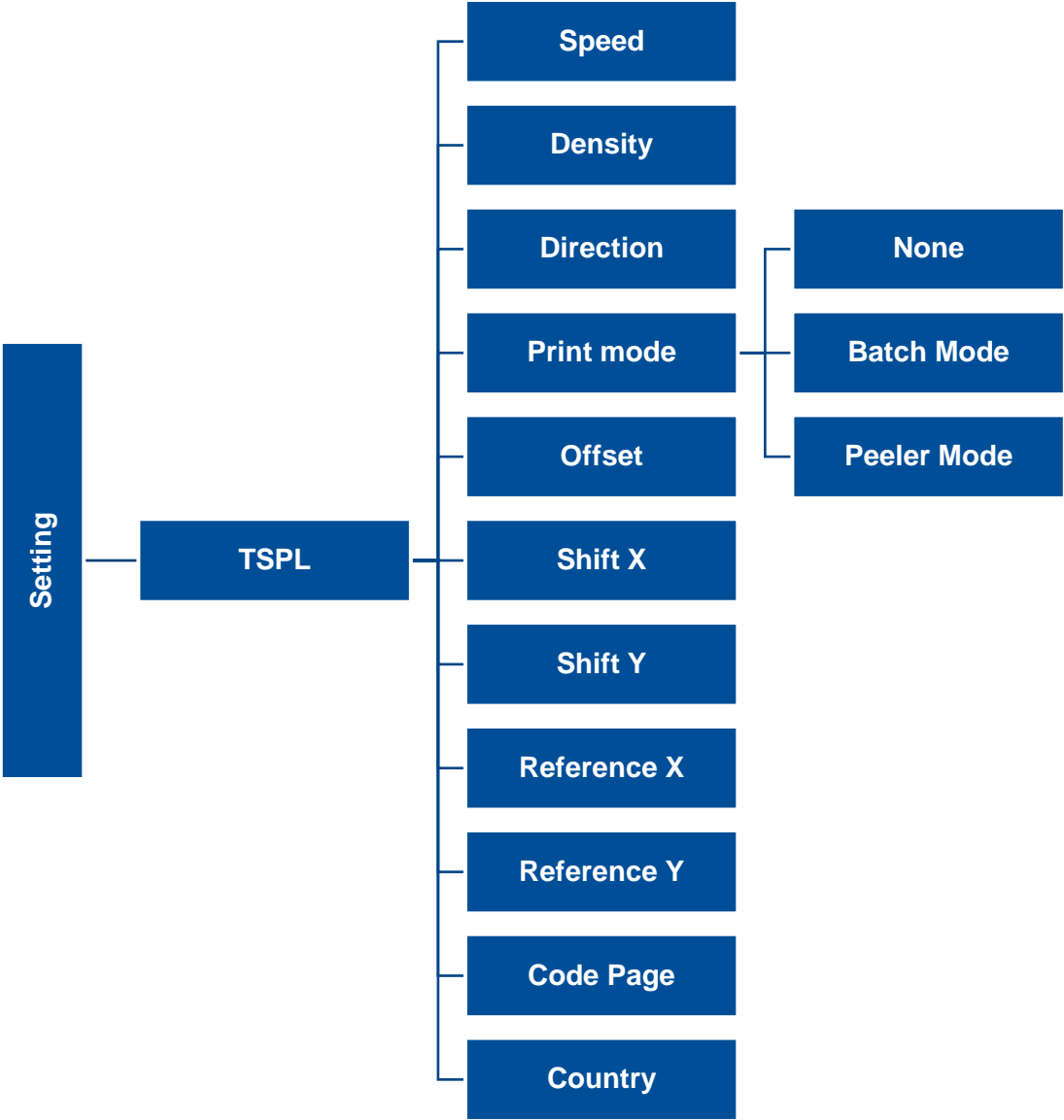

Item	Description	Default
Speed	Set the print speed.	N/A
Density	Set the printing darkness.	8
Direction	Set the printout direction. Setting Value: 0 and 1. Direction 0: <input type="text" value="Direction"/> Direction 1: <input type="text" value="Direction"/>	0
Print mode	Set the print mode. There are 5 modes in total: None: Next label top of form is aligned to the print head burn line location. (Tear Off Mode) Batch Mode: Once finishing the printing process, label will be fed to the tear plate location.	Batch Mode
Offset	Adjust media stop location. Available value setting range: -999 dots to 999 dots.	0 dot
Shift X	Adjust print position. Available value setting range: -999 dots to 999 dots.	0 dot
Shift Y		0 dot
Reference X	Set the origin of printer coordinate system horizontally and vertically. Available setting range: 0 dot to 999 dots.	0 dot
Reference Y		0 dot
Code page	Set the code page of international character set.	850
Country	Set the country code. Available setting value range: 1 to 358.	001

Note: If printing from enclosed software/driver, the software/driver will send out the commands, which will overwrite the settings set from the panel.

4.4 ZPL2

This "ZPL2" category can set up the printer settings for ZPL2.

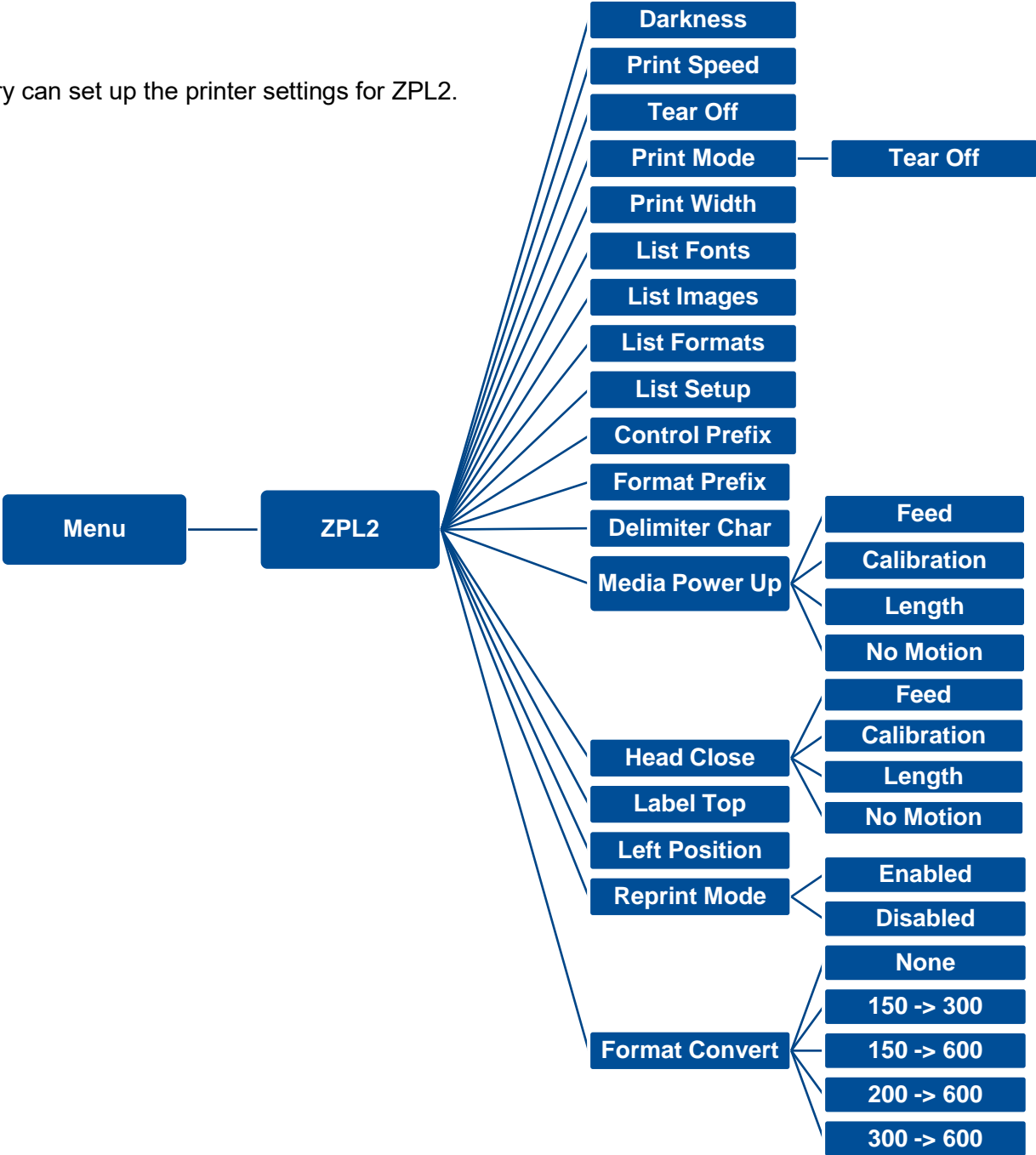

Item	Description	Default
Density	Set the printing darkness. Available setting range: 0 to 30.	16
Print Speed	Set the print speed.	6 (203dpi) 4 (300dpi) 3 (600dpi)
Tear Off	Adjust media stop location. Available setting value range: -120~120 dots.	0 dot
Print mode	Set the print mode. There are 4 modes: Tear Off: Next label top of form is aligned to the print head heating line location.	Tear Off
Print Width	Set the print width. Available setting range: 2 ~ 999 dots.	812
List Fonts	Print the current fonts list from the memory devices to the label.	N/A
List Images	Print current printer available images list stored at the memory device to the label.	N/A
List Formats	Print current printer available formats list from the memory devices to the label.	N/A
List Setup	Print current printer configuration to the label.	N/A
Control Prefix	Set control prefix character.	N/A
Format Prefix	Set format prefix character.	N/A
Delimiter Char	Set delimiter character.	N/A
Media Power Up	Set the action of the media when turning on the printer. Feed: Printer will advance one label. Calibration: Printer will make calibration. Length: Printer determine length and feed label. No Motion: Printer will not move media.	No Motion

Head Close	Set the action of the media when closing the print head. Feed: Printer will advance one label. Calibration: Printer will make calibration. Length: Printer determine length and feed label. No Motion: Printer will not move media.	No Motion
Label Top	Adjust print position vertically on the label. Value range: -120 to +120 dots.	0
Left Position	Adjust print position horizontally on the label. Value range:-9999 to +9999 dots.	0
Reprint Mode	Reprint the last label by pressing  button on printer's control panel.	Disabled
Format Convert	Select the bitmap scaling factor. The first number is the original dots per inch (dpi) value; the second the dpi which you would like to scale.	None

Note: printing from other software/drive will overwrite the settings set from the panel.

4.5 Sensor

This option is used to calibrate the selected sensor. We recommend calibrate the sensor before printing when changing the me

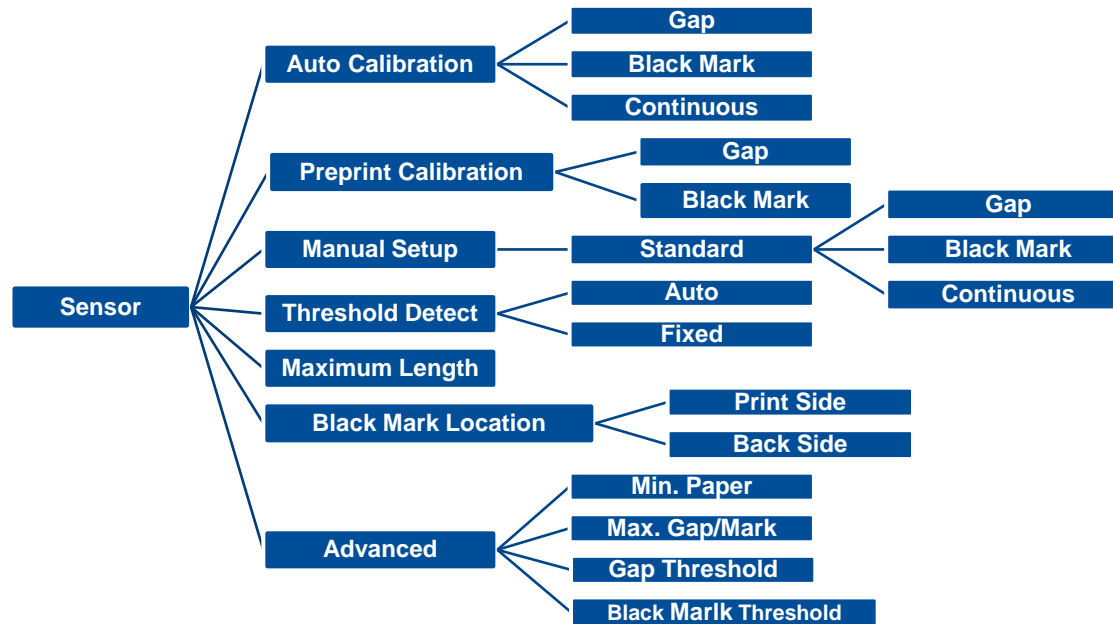

Item	Description	Default
Auto Calibration	Set the media sensor type and calibrate the selected sensor automatically.	N/A
Preprint Calibration	Set the preprint media sensor type and calibrate the selected sensor automatically. Note: For RFID with gap type media, it is recommended to use this “preprint calibration” item for sensor calibration.	N/A
Manual Calibration	In case Auto Calibration does not work, please use “Manual” function to set the paper length and gap/bline size to complete the calibration setting.	N/A
Threshold Detect	Set sensor sensitivity in fixed or auto.	Auto
Maximum Length	Set the maximum length for label calibration.	254 mm
Black Mark Location	This option is used to set upper or lower black mark sensor as the main transmitter.	Back side
Advanced	Set the minimum paper length and maximum gap/bline length for auto-calibration and set the sensor threshold.	0 mm 0 mm 65% 50%

4.6 Interface

Interface can set the printer interface settings.

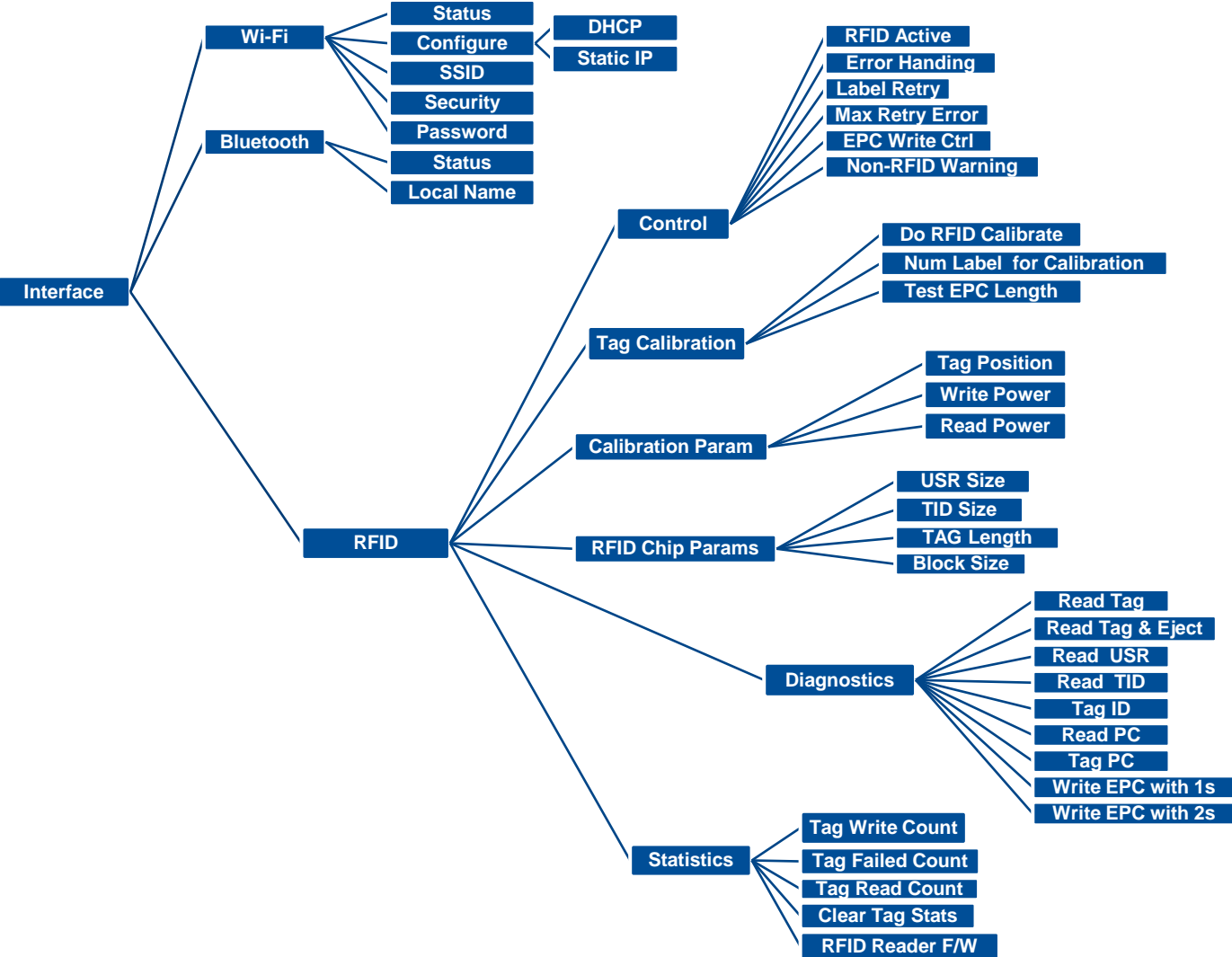

	Item	Description	Default
Wi-Fi	Status	Check the Wi-Fi status	N/A
	Configure	Set the Wi-Fi configure	DHCP
	SSID	Set the SSID	N/A
	Security	Set the security	Open
	Password	Set the security key	N/A
Bluetooth	Status	Check the Bluetooth status	N/A
	Local Name	Set the local name for Bluetooth	N/A
RFID	Control	RFID Active: Select ON/OFF to enable/disable the RFID encoder module.	

Error Handling:

This menu item selects the error handling mode for RFID failures.

Overstrike (Default)	Each failed label prints with the Overstrike pattern and the form retries on a new label until the Label Retry count is exhausted. Whether or not an error message will display or the failed label will reprint depends upon the <i>Max Retry Error</i> setting.
None	No specific action is taken when a tag fails to be programmed.
Stop	The printer will halt and display the error message "RFID Error: Check Media." The label is discarded and reprinting of the label (if desired) must be initiated from the host. When the error is cleared, the label with the failed tag moves forward until the next label is in position to be printed.

Label Retry:

This menu item selects the number of label retries that the RFID encoder will attempt before declaring a fault. This may indicate a problem with the RFID encoder, the coupler assembly, the printer setup, or the label stock.

Minimum	1
Maximum	10 (Default)

Max Retry Error:

This menu item determines if errors are declared when the *Label Retry* count is exceeded.

EPC Write Ctrl:

This option controls how the printer encodes the RFID tag EPC field.

Non-RFID Warning:

This menu item enables a warning to appear if the printer receives a print job that does not contain any RFID commands when RFID media is installed in the printer.

RFID**Tag Calibration**

This submenu is used to do RFID calibration. The user must do the tag calibration when installing a new tag in the printer. RFID calibration operation determines the RFID chip type, the write/read power, program position, length of the EPC/User field.

Do RFID Calibrate	<p>The executable item performs RFID calibration. This item should be executed when changing the RFID tag type.</p> <p>Note: Before performing an RFID calibration, you will first need to select the right sensor for your RFID labels and run a media sensor calibration. Please refer to ch. 3.8.3 for more information.</p>						
Num Label for Calibration	<p>The menu item determines how many tags to use for calibration. However, this value does not include tags moved when seeking gaps during the calibration process. Depending on the difficulty in calibrating the installed tags, the number of labels used could be more or less, but generally, the larger number chosen in this menu, the more tags that will be averaged together to determine the calibration result. Usually, this value should be left at the default value.</p> <table border="1"> <tr> <td>Minimum</td> <td>3 (Default)</td> </tr> <tr> <td>Maximum</td> <td>7</td> </tr> </table>	Minimum	3 (Default)	Maximum	7		
Minimum	3 (Default)						
Maximum	7						
Test EPC Length	<p>The menu item determines the size of the EPC data that will be used to perform the RFID Calibration. This menu can be increased to improve the accuracy of the RFID Calibration, but it should not be increased to a value greater than the maximum EPC length that the current Tag Type can support.</p> <table border="1"> <tr> <td>Minimum</td> <td>16</td> </tr> <tr> <td>Maximum</td> <td>256</td> </tr> <tr> <td>Default</td> <td>96</td> </tr> </table>	Minimum	16	Maximum	256	Default	96
Minimum	16						
Maximum	256						
Default	96						

Calibration Param

It will contain the settings used for optimal tag encoding. These parameters can be obtained automatically through RFID Calibration.

Tag Position	<p>This menu determines how far the RFID tag encoding position of the currently installed tag should be offset from Top of Form.</p>				
Write Power	<p>This menu item selects the write power level to be used in the RFID encoder. Normally, this value is set auto-matically by the RFID calibration process and should not be changed.</p> <table border="1"> <tr> <td>Minimum</td> <td>1</td> </tr> <tr> <td>Maximum</td> <td>25</td> </tr> </table>	Minimum	1	Maximum	25
Minimum	1				
Maximum	25				
Read Power	<p>This menu item selects the read power level to be used in the RFID encoder. Normally, this value is set automatically by the RFID calibration process and should not be changed.</p> <table border="1"> <tr> <td>Minimum</td> <td>1</td> </tr> <tr> <td>Maximum</td> <td>25</td> </tr> </table>	Minimum	1	Maximum	25
Minimum	1				
Maximum	25				

RFID**RFID Chip Param**

It is used to configure the system when support of custom RFID tags is required.

USR Size	<p>This menu item selects the size in bytes of the USR block within the RFID tag memory. Normally, this value is set automatically by the RFID calibration process and should not be changed.</p> <table border="1" data-bbox="696 261 1193 325"> <tr> <td>Minimum</td> <td>0 (Default)</td> </tr> <tr> <td>Maximum</td> <td>256</td> </tr> </table> <p>Note: This value will be hidden if Higgs3 tags are detected, and the Higgs 3 USR Len menu will be unhidden instead.</p>	Minimum	0 (Default)	Maximum	256		
Minimum	0 (Default)						
Maximum	256						
TID Size	<p>This menu item indicates the size of the memory block within the RFID tag memory that contains the Tag ID. Normally, this value is set automatically by the RFID calibration process and should not be changed.</p> <table border="1" data-bbox="696 496 1193 592"> <tr> <td>Minimum</td> <td>0</td> </tr> <tr> <td>Maximum</td> <td>12</td> </tr> <tr> <td>Default</td> <td>8</td> </tr> </table>	Minimum	0	Maximum	12	Default	8
Minimum	0						
Maximum	12						
Default	8						
Higgs 3 USR Len	<p>Higgs 3 tags differ from other RFID tags in that its memory bank size is not fixed. To accommodate EPC lengths longer than 96 bits, Higgs 3 borrows memory from the USR bank. This display only menu indicates the size in bits of the USR block within the RFID tag memory.</p> <table border="1" data-bbox="696 703 1193 767"> <tr> <td>Minimum</td> <td>128</td> </tr> <tr> <td>Maximum</td> <td>512 (Default)</td> </tr> </table> <p>Note: This menu will only be shown if a Higgs 3 tag is detected. Otherwise, it will be hidden.</p>	Minimum	128	Maximum	512 (Default)		
Minimum	128						
Maximum	512 (Default)						
Higgs 3 EPC Len	<p>Higgs 3 tags differ from other RFID tags in that its memory bank size is not fixed. To accommodate EPC lengths longer than 96 bits, Higgs 3 borrows memory from the USR bank. This menu item selects the number of bits dedicated to the EPC block within the RFID tag memory.</p> <table border="1" data-bbox="696 951 1193 1046"> <tr> <td>Minimum</td> <td>96</td> </tr> <tr> <td>Maximum</td> <td>480</td> </tr> <tr> <td>Default</td> <td>96</td> </tr> </table> <p>Note: This menu will only be shown if a Higgs 3 tag is detected. Otherwise, it will be hidden.</p>	Minimum	96	Maximum	480	Default	96
Minimum	96						
Maximum	480						
Default	96						
TAG Length	<p>This menu item selects the number of bytes in the EPC block within the RFID tag memory. Normally, this value is set automatically by the RFID calibration process and should not be changed.</p> <table border="1" data-bbox="696 1198 1193 1294"> <tr> <td>Minimum</td> <td>8</td> </tr> <tr> <td>Maximum</td> <td>64</td> </tr> <tr> <td>Default</td> <td>12</td> </tr> </table> <p>Note: This value will be hidden if Higgs3 tags are detected, and the Higgs 3 EPC Len menu will be unhidden instead.</p>	Minimum	8	Maximum	64	Default	12
Minimum	8						
Maximum	64						
Default	12						

Block Size	This menu item selects the maximum number of bytes written to the USR block within the RFID tag memory at one time. Normally, this value is set automatically by the RFID calibration process and should not be changed.	
	Minimum	0
	Maximum	32
	Default	8

Diagnostics It is used to run test procedures to help determine the accuracy and troubleshoot the RFID system.

Read Tag	This executable menu reads the tag in range of the internal RFID coupler and reports the tag data to the debug port and momentarily displays it on the control panel's LCD. It is primarily intended for development verification by checking that the system is working. Note: This menu item does not position the RFID tag over the coupler. Make sure to position the tag over the coupler to receive an accurate reading.
Read Tag & Eject	This executable menu works exactly the same as <i>Read Tag</i> executable, except that after the printer reads the tag, it feeds the label to the next top-of-form. Note: This menu item does not position the RFID tag over the coupler. Make sure to position the tag over the coupler to receive an accurate reading.
Read USR	This executable menu reads the User Memory bank of the tag in range of the internal RFID coupler and reports the data to the debug port and momentarily displays it on the control panel's LCD. It is primarily intended for development verification by checking that the system is working. Note: This menu item does not position the RFID tag over the coupler. Make sure to position the tag over the coupler to receive an accurate reading.
Read TID	This executable menu reads the TID (Tag ID) from the tag in range of the internal RFID coupler and displays the value read in the <i>Tag ID</i> menu. Note: This menu item does not position the RFID tag over the coupler. Make sure to position the tag over the coupler to receive an accurate reading.
Tag ID	This menu item displays the first TID (Tag ID) read since power-up, or if using the <i>Read TID</i> menu, the most recently read TID. If no tag is in range of the internal RFID coupler, "Unknown" displays.
Read PC	This executable menu reads the PC (Protocol Control) field from an RFID tag in range of the internal RFID coupler and displays the value read in the Tag PC menu. Note: This menu item does not position the RFID tag over the coupler. Make sure to position the tag over the coupler to receive an accurate reading.
Tag PC	This menu item displays the last PC (Protocol Control) field read from an RFID tag. If no tag is in range of the internal RFID coupler, "Unknown" displays.
Write EPC with 1s	This executable menu writes all ones to the tag in range of the internal RFID coupler. It is primarily intended for development verification by checking that the system is working. Note:

	This menu item does not position the RFID tag over the coupler. Make sure to position the tag over the coupler to receive an accurate writing.
Write EPC with 2s	This executable menu writes all twos to the tag in range of the internal RFID coupler. It is primarily intended for development verification by checking that the system is working. Note: This menu item does not position the RFID tag over the coupler. Make sure to position the tag over the coupler to receive an accurate writing.

Statistics

It is general read-only and used to gather and report statistics on how the RFID system is reporting on print jobs sent to the printer.

Tag Write Count	This menu item displays on the LCD the number of tags attempted to be written since the last Clear Tag Stat operation has been initiated.
Tag Failed Count	This menu item displays on the LCD the number of failed RFID tags since the last Clear Tag Stat operation has been initiated.
Tag Read Count	This menu item displays the number of tags read since the last Clear Tag Stat operation.
Clear Tag Stat	This executable menu item clears the Count menu items in this submenu.
RFID Reader F/W	Shows the RFID firmware version installed in the encoder.
RFID Reader Hd/W	Shows the RFID hardware version installed in the encoder.

4.7 File Manager

File Manager is used to check the printer available memory, show the files list, delete the files or run the files that saved in the printer DRAM/Flash/Card memory.



Item	Description
DRAM	Use this menu to show, delete and run (.BAS) the files saved in the printer DRAM memory.
FLASH	Use this menu to show, delete and run (.BAS) the files saved in the printer Flash memory.
CARD	Use this menu to show, delete and run (.BAS) the files saved in the SD card on printer. Note: This subsection will only be visible when the SD card is installed.

4.8 Diagnostic

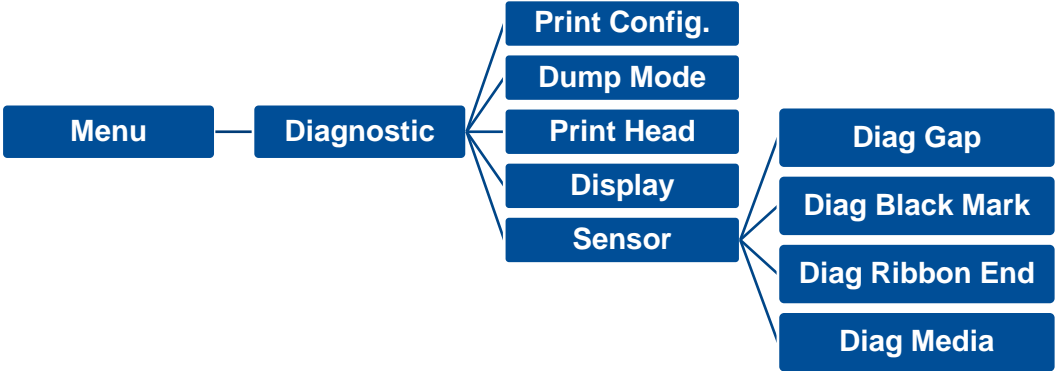

Item

Description

Print Config.

Print current printer configuration to the label. The configuration printout contains print head test pattern, which is useful for checking the dot damage on the print head heater.

Captures the data from the communications port and prints out the data received by printer. In the dump mode, all characters will be printed in 2 columns. The left side characters are received from your system and right side data are the corresponding hexadecimal value of the characters. It allows users or engineers to verify and debug the program.

Dump mode requires 4" wide paper width.

Dump Mode

```

DOWNLOA 0D 0A 44 4F 57 4E 4C 4F 41
D „TEST2. 44 20 22 54 45 53 54 32 2E
DAT“,5,CL 44 41 54 22 2C 35 2C 43 4C
S DOWNLO 53 0D 0A 44 4F 57 4E 4C 4F
AD F,“TES 41 44 20 46 2C 22 54 45 53
T4.DAT“,5 54 34 2E 44 41 54 22 2C 35
,CLS DOW 2C 43 4C 53 0D 0A 44 4F 57
NLOAD „TE 4E 4C 4F 41 44 20 22 54 45
ST2.DAT“, 53 54 32 2E 44 41 54 22 2C
5,CLS DO 35 2C 43 4C 53 0D 0A 44 4F
WNLOAD F, 57 4E 4C 4F 41 44 20 46 2C
„TEST4.DA 22 54 45 53 54 34 2E 44 41
T“,5,CLS 54 22 2C 35 2C 43 4C 53 0D
DOWNLOAD 0A 44 4F 57 4E 4C 4F 41 44
„TEST2.D 20 22 54 45 53 54 32 2E 44
AT“,5,CLS 41 54 22 2C 35 2C 43 4C 53
DOWNLOAD 0D 0A 44 4F 57 4E 4C 4F 41
D F,“TEST 44 20 46 2C 22 54 45 53 54
4.DAT“,5, 34 2E 44 41 54 22 2C 35 2C
CLS 43 4C 53 0D 0A
  
```

Print Head Check print head's temperature and bad dots.

Display Check LCD's color state.

Sensor Check sensors intensity and reading state.

4.9 Advanced

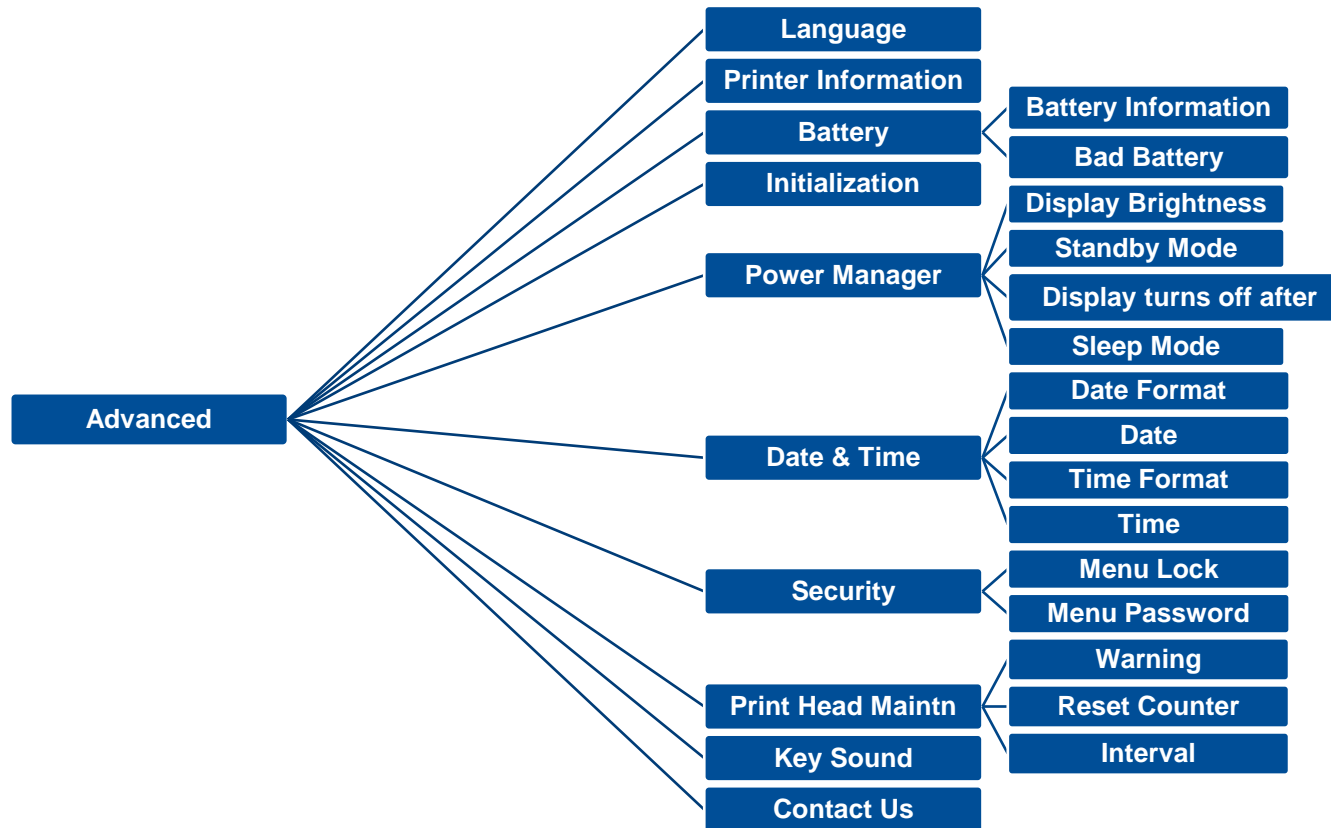

Item	Description	Default
Language	Setup the language on display.	English
Printer Information	Check the printer serial number, printed mileage (m), printed labels (pcs), etc.	N/A
Battery	Check the battery information and to set the warning for discharge times.	550 times
Initialization	Restore printer settings to defaults.	N/A

Power Manager	Setup the brightness for display, standby mode, display turns off time and sleep mode.	Brightness: 50 Standby Mode: ON Display turns off after: 120 sec. Sleep Mode: OFF
----------------------	--	--

Date & Time	Setup the date and time on display.	N/A
------------------------	-------------------------------------	------------

Security	Set the password for locking the menu. The default password is 8888.	Disable
-----------------	--	----------------

Check print head status and to set the settings for print head care.

Printer Head Maintn	Item	Description	Disable
	Warning	To enable/disable the print head clean warning. If enable this feature, once print head has been reached the setting mileage then the warning icon will be shown on printer UI for reminding user to clean the print head. The default setting is disable.	
	Reset Counter	To reset the print head clean warning mileage after cleaned print head.	
	Interval	To set the expected mileage for reminding user to clean the print head. Enable the "TPH warning lock" for this function. The default setting is 1 km.	

Key Sound	This feature is used to ON/OFF the printer key sound	ON
------------------	--	-----------

Contact us	This feature is used to check the contact information for tech support service	N/A
-------------------	--	------------

5. TSC Console

TSC Console is a management tool combining the Printer Management, Diagnostic Tool, CommTool and Printer Webpage settings, which enables you to adjust printer's settings/status; change printers' settings; download graphics, deploy fonts, graphics, label templates or upgrade the firmware to the group of printers, and send additional commands to printers at the same time.

※ **Printer firmware version before A2.12 will only use 9100 Port as command port; Printer firmware after A2.12 will use 6101 Port as command port.**

5.1 Start TSC Console

1. Double click TSC Console icon to start the software.

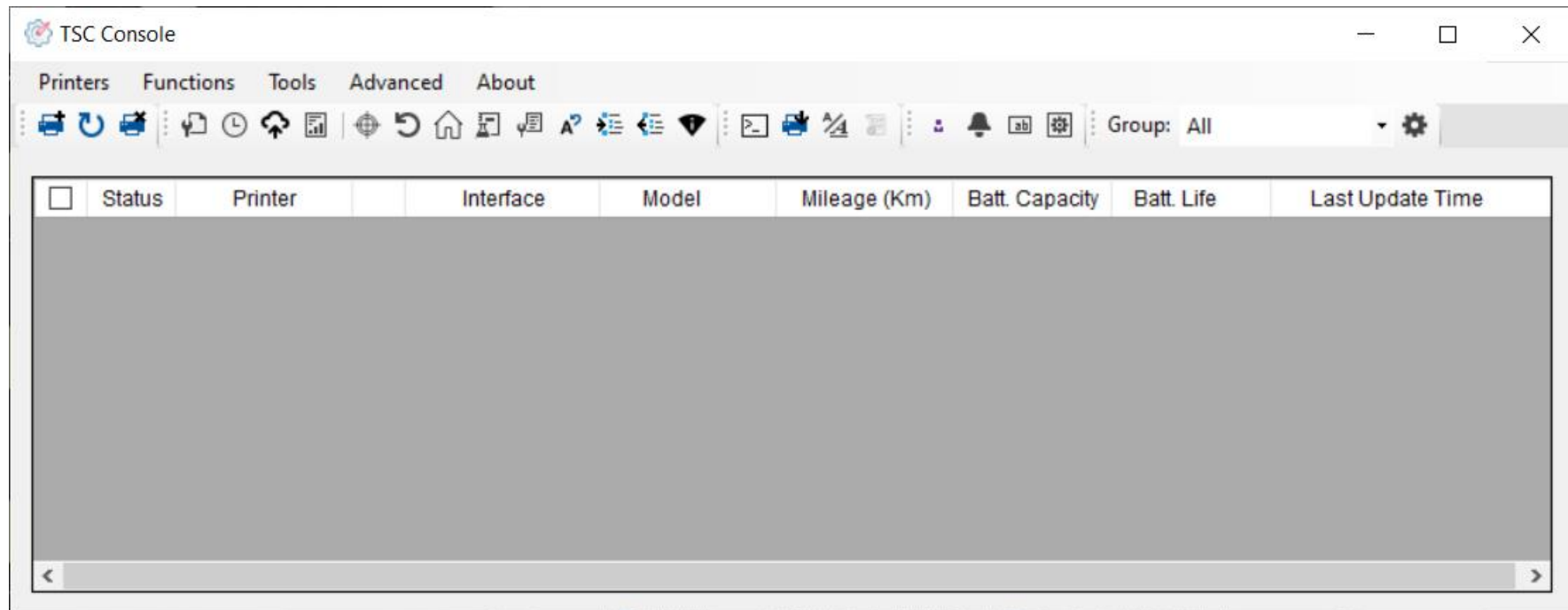

2. Manually add the devices by clicking **Printer > Add Printers**.

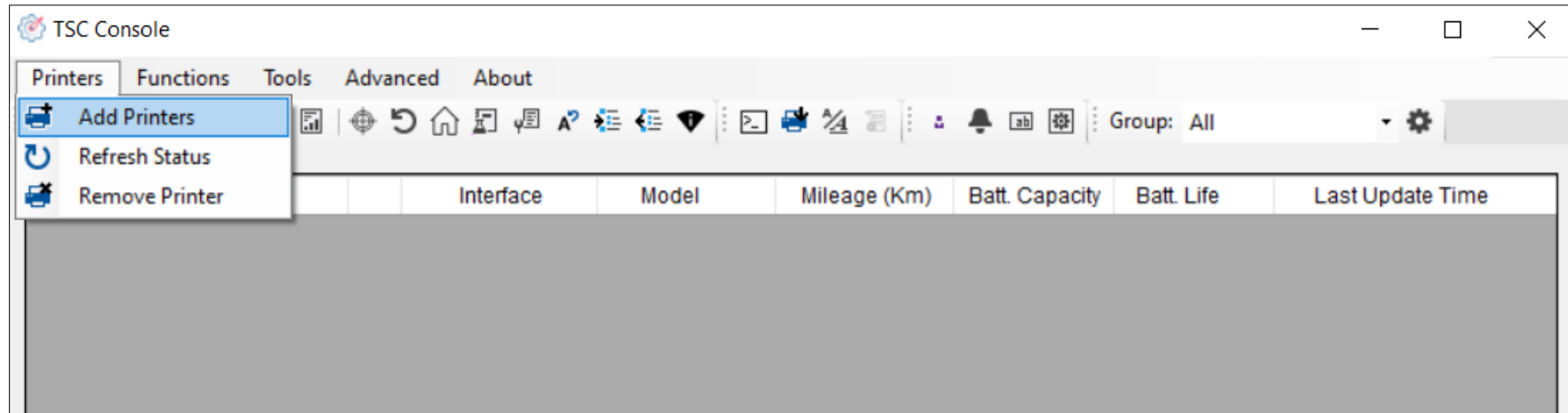

3. Select the current interface of the printer.

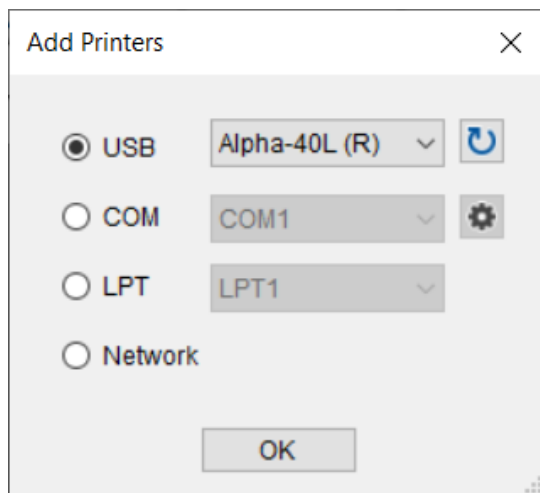

4. The printer will be added to **TSC Console's** interface.

5. Select the printer and set the settings.

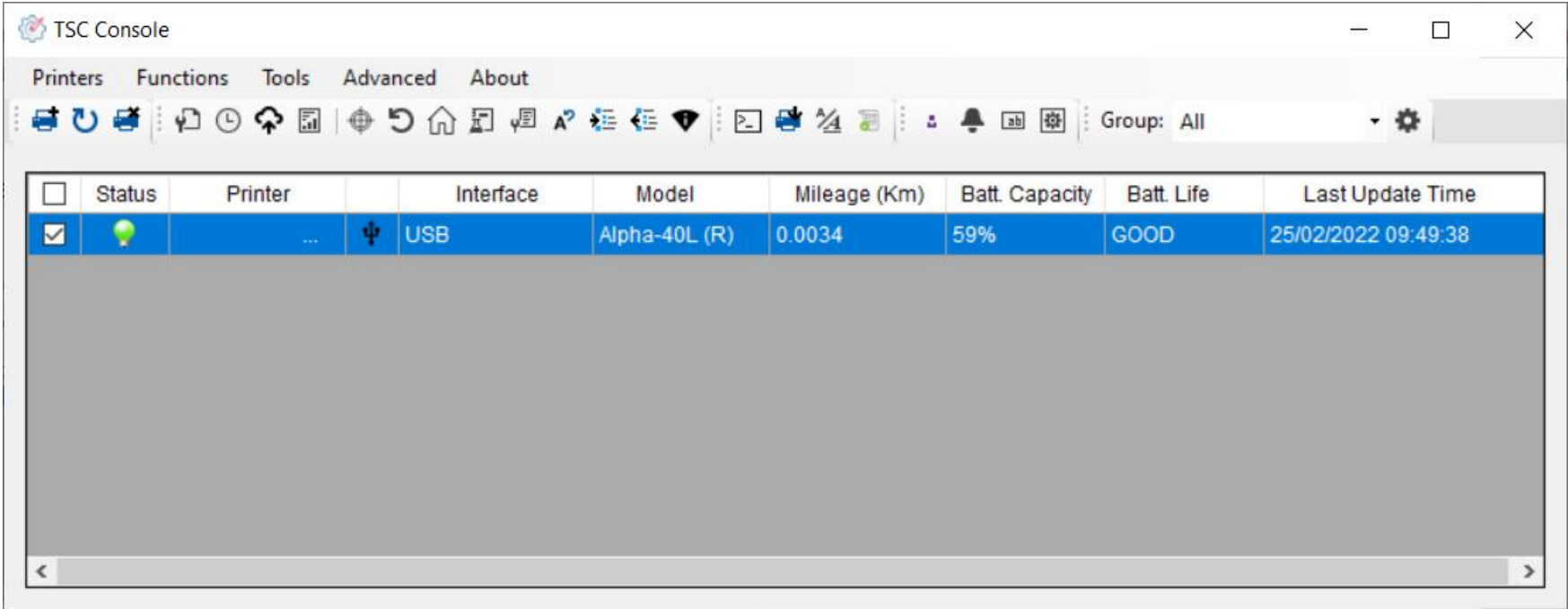

For more information, please refer to TSC Console User Manual.

5.2 Set Wi-Fi and Add to TSC Console Interface

- 1. Use **USB** or **COM Port** to set up the interface.
(refer to chp.5.1)
- 2. Double click to enter the printer configuration page.

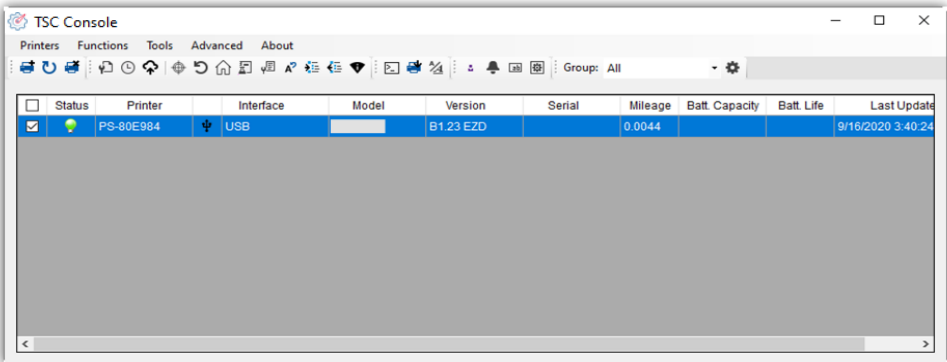

- 3. Click **Get** to receive printer's information.
- 4. Click **Wi-Fi** to the wi-fi setting page.

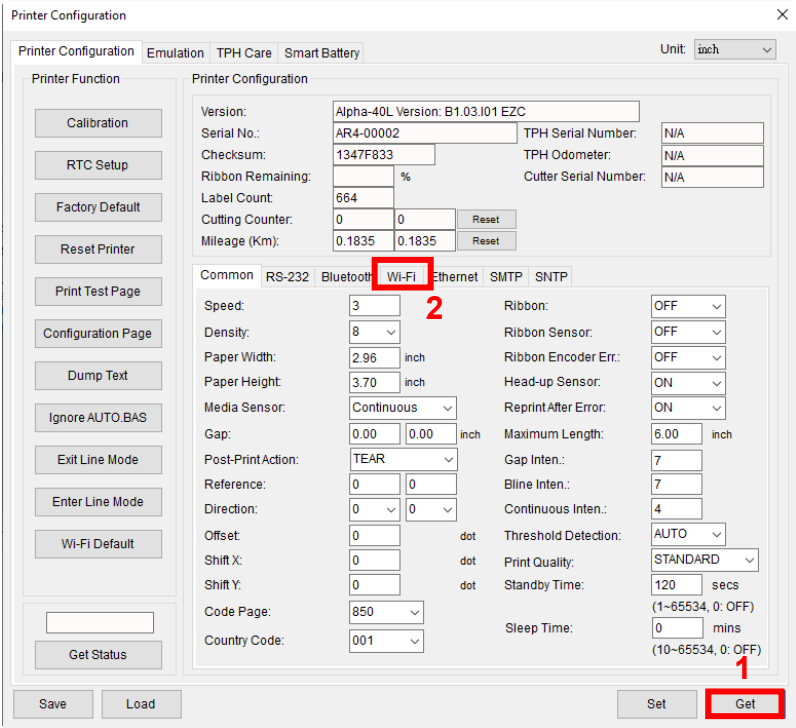

For WPA-Personal

- I. Fill-in the **SSID**.
- II. Select the Encryption option to **WPA-Personal**.
- III. Fill-in the Key.
- IV. Select **DHCP** to **ON**. (For **OFF** option, please fill-in the IP Address, Subnet Mask and Gateway)
- V. After setting, click the **Set** button.

Note:

Before setting, the entered field will be shown in yellow for reminding.

On DHCP, user can change the printer name by another model name in "Printer Name" field.

User also can change the raw port in "Raw Port" field.

Common RS-232 Bluetooth Wi-Fi Ethernet SMTP SNTP

Built-in Wi-Fi Module

SSID: SSID_1

WLAN Encryption: WPA-Personal

Key: *****

DHCP: ON

IP Address: 1

Subnet Mask: 0.0.0.0

Gateway:

Primary DNS IP:

Secondary DNS IP:

Raw Port: 9100

Printer Name: PS-FF153C

MAC Address: 00:1B:82:FF:15:3C

EAP Type:

Username:

Password:

File Name Browse

CA Certificate:

Client Certificate:

Private Key:

EAP-FAST PAC:

Wi-Fi Version: 3.7.1.0R6

RSSI: 0

Set Get

For WPA-Enterprise

- I. Fill-in the **SSID**.
- II. Select the Encryption option to **WPA2-Enterprise**.
- III. Select DHCP to **ON** (For **OFF** option, please fill-in the IP Address, Subnet Mask and Gateway)
- IV. Select the **EAP Type** option. (For **EAP-TLS** option, please upload the CA and Key for mutual authentication, integrity-protected cipher suite negotiation, and key exchange between two endpoints.)
- V. After setting, click the **Set** button.

Note:

Before setting, the entered field will be shown in yellow for reminding.

On DHCP, user can change the printer name by another model name in "Printer Name" field.

User also can change the raw port in "Raw Port" field.

Common RS-232 Bluetooth Wi-Fi Ethernet SMTP SNTP

Built-in Wi-Fi Module

SSID: SSID_2

WLAN Encryption: WPA2-Enterprise

Key: *****

DHCP: ON

IP Address: 1

Subnet Mask: 0.0.0.0

Gateway:

Primary DNS IP:

Secondary DNS IP:

Raw Port: 9100

Printer Name: PS-FF153C

MAC Address: 00:1B:82:FF:15:3C

EAP Type:

Username:

Password:

File Name Browse

CA Certificate:

Client Certificate:

Private Key:

EAP-FAST PAC:

Wi-Fi Version: 3.7.1.0R6

RSSI: 0

Set Get

5. After clicking “Set” button, it'll pop-up the window tip as below shown.

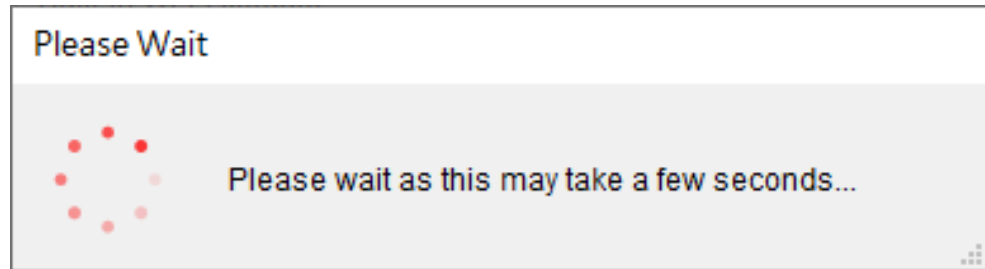

6. IP address will be shown in the “IP address” field and the Wi-Fi logo and IP address will be displayed on the LCD control panel as shown below. The Wi-Fi module has been connected.

Note:

IP address should be shown within about 5~15 seconds after printer turn on. If not, please refer to steps below to initialize the printer Wi-Fi module settings then to setup it again.

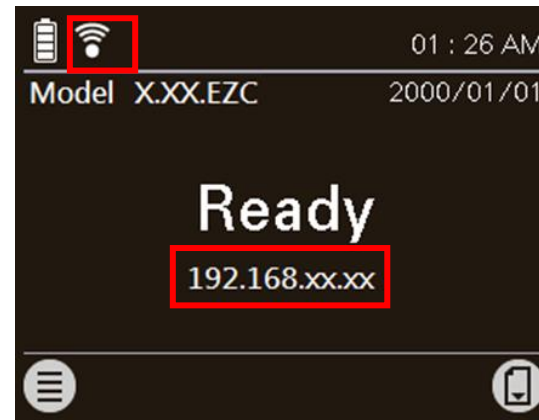

7. Remove the Type C cable between the computer and the printer.
8. Go to main page, click Add Printer to add the printer via Network.
9. Select the printer and enter the setting page by double clicking the printer.
10. Click the "Print Test Page" button to print the test page via Wi-Fi interface.

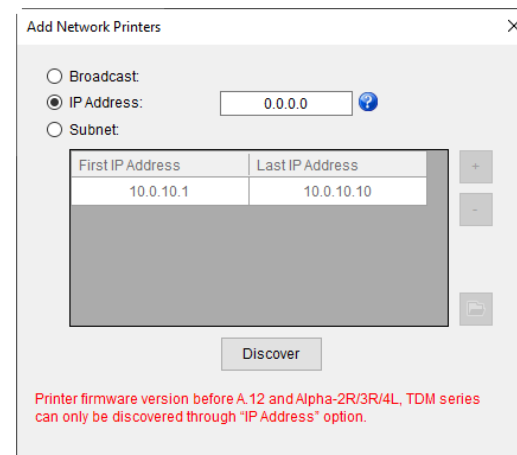

5.3 Initialize the Printer Wi-Fi Setting

1. Return to the main page of TSC Console.

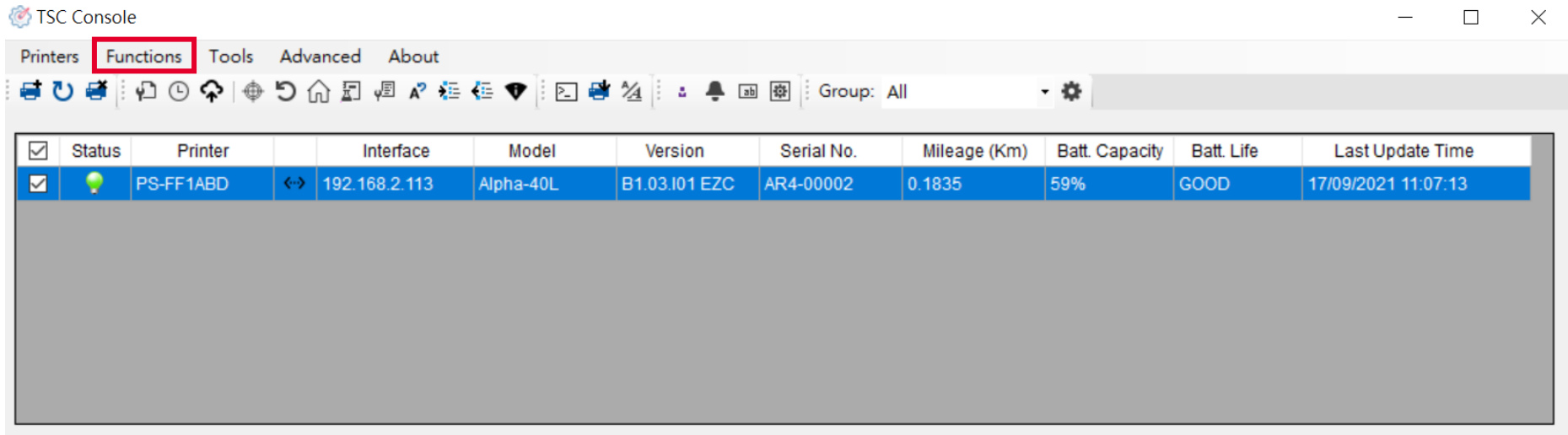

2. Click **Functions** to expand the page.
3. Click **Wi-Fi Default** to initialize the printer Wi-Fi module setting to factory default setting.

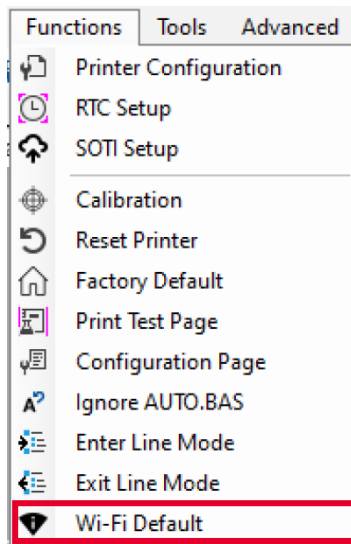

5.4 TPH Care

TPH Care provides users to check the condition of the print head and be able to set the dot failure threshold for indicating errors when the threshold is triggered.

This option is used to enable (ON)/ disable (OFF) the TPH care function.

This option is used to check the numbers of unhealthy TPH dot element.

This option is used to detect the unhealthy TPH dot.

This option is used to set the threshold for unhealthy TPH dot number.

This image is used to check the relative position of the unhealthy TPH dot.

This option is used to print a TPH test image to check the TPH printing result.

1. Enable the TPH Care function. (Note: The default is disabled/OFF.) Then click "Get TPH care profile" button and a diagram will show in the area above.
2. If the profile is flat, it means that the print head is good. Check "Unhealthy TPH dot number". If the result is zero (0), that means the print head is good.
3. Bad dots are presented as a spike in the profile. The arrow in below iprofile indicates the presence of potentially damaged dots and printer will stop printing.

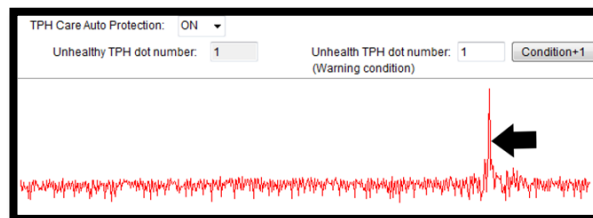

5.5 Printer Function

Printer Function could be found in **Printer Configuration**. “Printer Function” will be shown on the left side of the window.

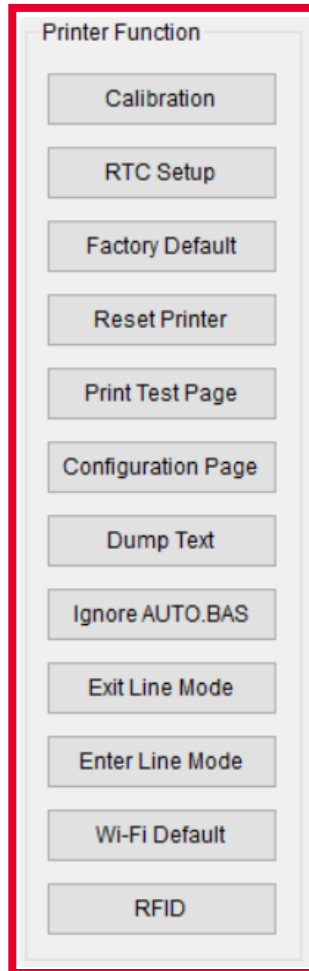

Functions	Description
Calibrate Sensor	Detect media types and the size of the label
RTC Setup	Synchronize printer with Real Time Clock on PC
Factory Default	Initialize the printer to default settings
Reset Printer	Reboot printer
Print Test Page	Print test page according to the specified label size and sensor type.
Configuration Page	Print printer configurations
Dump Text	Activate the printer to dump mode
Ignore AUTO.BAS	Ignore AUTO.BAS file when printer boot up
Exit Line Mode	Exit the line mode to page mode
Enter Line Mode	Leave page mode and enter line mode
WiFi Default	Restore the WiFi settings to defaults
RFID	Enter RFID setting/ checking table

5.6 Setting RFID

Press **[RFID]** button from **Printer Function** to enter the RFID menu on TSC Console. Here provides users to set the RFID common settings, RFID calibration and checking statistics.

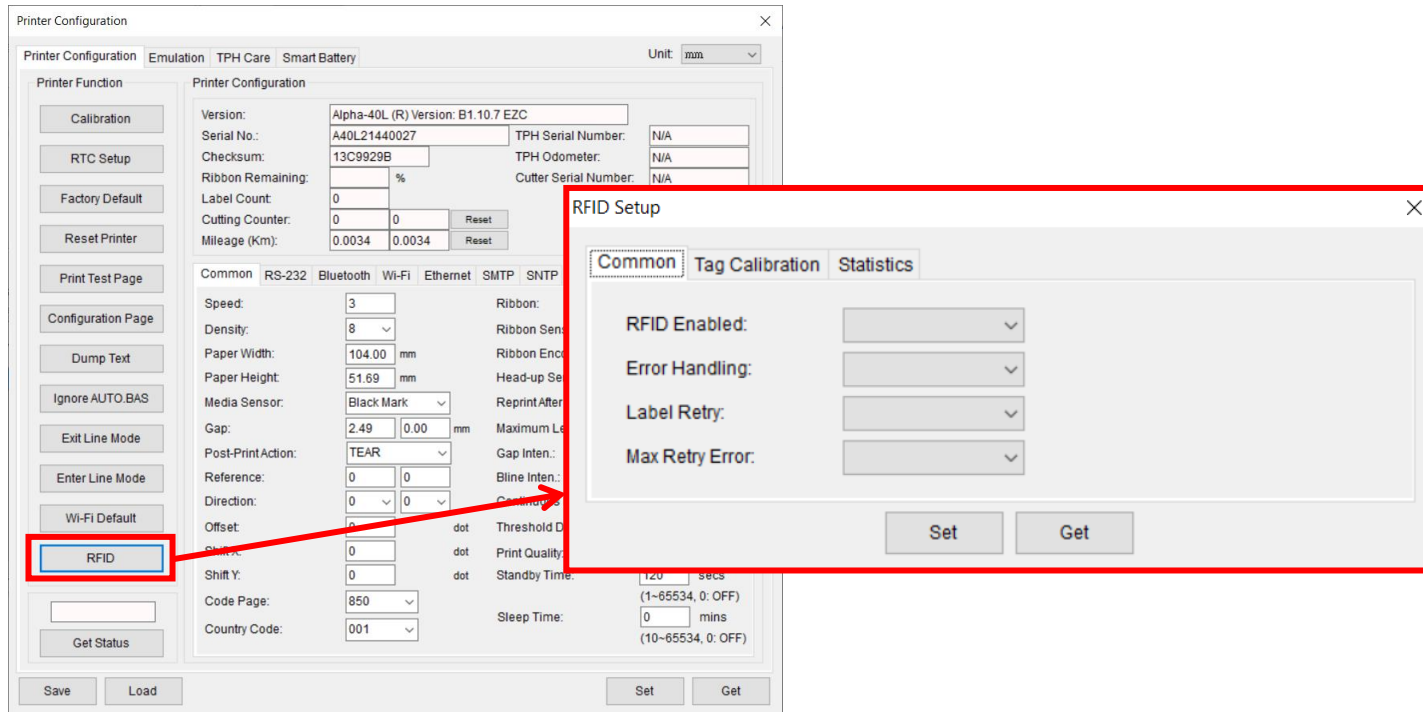

Tab	Item	Description
Common	RFID Enabled:	OFF/ ON Select ON/OFF to enable/disable the RFID encoder module.
	Error Handling:	OFF/ STOP/ OVERSTRIKE This menu item selects the error handling mode for RFID failures.
	Label Retry:	1~10 This menu item selects the number of label retries that the RFID encoder will attempt before declaring a fault.
	Max Retry Error:	OFF/ ON This menu item determines if errors are declared when the <i>Label Retry</i> count is exceeded.

<p>Tag Calibration</p>	<p>Tag Position: <input type="text" value="232"/> dot RFID Calibration</p> <p>Write Power: <input type="text" value="18"/> ▾</p> <p>Read Power: <input type="text" value="16"/> ▾</p>	<p>This RFID button is used to do RFID calibration, and get the three parameters through RFID calibration.</p> <p>Note: Before performing an RFID calibration, you will first need to select the right sensor for your RFID labels and run a media sensor calibration.</p>
<p>Statistics</p>	<p>Tag Write Count <input type="text" value="0"/> Reset Counter</p> <p>Tag Failed Count <input type="text" value="0"/></p> <p>Tag Read Count <input type="text" value="0"/></p>	<p>It is read-only and used to show the number of tags attempted to be written/ failed/ read RFID tags since the last Clear Tag Stat operation has been initiated.</p> <p>Press “Reset Counter” button to Clear Tag Stat.</p>

Note: Please refer to Ch. 4.6 Interface for more information.

6. Troubleshooting

6.1 Common Problems

The following guide lists the most common problems that might be encountered when operating this bar code printer. If the printer still does not function after all suggested solutions have been invoked, please contact the Customer Service Department of your purchased reseller or distributor for assistance.

Problem	Possible Cause	Recovery Procedure
No Power	<ul style="list-style-type: none"> ■ The battery is not properly installed. ■ Battery out of power. ■ Battery damage. 	<ul style="list-style-type: none"> ■ Reinstall the battery. ■ Switch the printer on. ■ Charge the battery. ■ Replace a new battery.
Not Printing	<ul style="list-style-type: none"> ■ Check if interface cable is well connected to the interface connector. ■ Check if wireless or Bluetooth device is well connected between host and printer. ■ The port specified in the Windows driver is not correct. 	<ul style="list-style-type: none"> ■ Re-connect cable to interface change a new cable. ■ Please reset the wireless device setting. ■ Select the correct printer port in the driver. ■ Check your program if there is a command PRINT at the end of the file and there must have CRLF at the end of each command line.
No print on the label	<ul style="list-style-type: none"> ■ Label loaded not correctly ■ Use wrong type paper 	<ul style="list-style-type: none"> ■ Follow the instructions in loading the media. ■ Use thermal type paper
The printer status from LCD shows “Carriage Open”.	<ul style="list-style-type: none"> ■ The printer carriage is open. 	<ul style="list-style-type: none"> ■ Please close the print carriage.
The printer status from LCD shows “No Paper”.	<ul style="list-style-type: none"> ■ Running out of media roll. ■ The media is installed incorrectly. ■ Media sensor is not calibrated. 	<ul style="list-style-type: none"> ■ Supply a new media roll. ■ Follow the instructions in loading the media to reinstall the media roll. ■ Calibrate the media sensor.
The printer status from LCD shows “Paper Jam”.	<ul style="list-style-type: none"> ■ Media sensor is not set properly. ■ The media size is set incorrectly. ■ Label may be stuck inside the printer mechanism. 	<ul style="list-style-type: none"> ■ Calibrate the media sensor. (Select the correct sensor) ■ Set media size correctly. ■ Remove the stuck label inside the printer mechanism.
Can't downloading the file to memory (FLASH / DRAM/CARD)	<ul style="list-style-type: none"> ■ The space of memory is full. 	<ul style="list-style-type: none"> ■ Delete unused files in the memory.

SD card is unable to use	<ul style="list-style-type: none"> ■ SD card is damaged. ■ SD card doesn't insert correctly. 	<ul style="list-style-type: none"> ■ Use the supported capacity SD card. ■ Insert the SD card again.
Poor Print Quality	<ul style="list-style-type: none"> ■ Media is loaded incorrectly ■ Dust or adhesive accumulation on the print head. ■ Print density is not set properly. ■ Print speed is not set properly. ■ Print head element is damaged. 	<ul style="list-style-type: none"> ■ Reload the supply. ■ Clean the print head. ■ Clean the platen roller. ■ Adjust the print density and print speed. ■ Run printer self-test and check the print head test pattern if there is dot missing in the pattern. ■ Change proper media roll. ■ Make sure the print carriage is closed properly.
Missing printing on the left or right side of label	<ul style="list-style-type: none"> ■ Wrong label size setup. 	<ul style="list-style-type: none"> ■ Set the correct label size.
Irregular printing	<ul style="list-style-type: none"> ■ The printer is in Hex Dump mode. 	<ul style="list-style-type: none"> ■ Turn off and on the printer to skip the dump mode.
Skip labels when printing	<ul style="list-style-type: none"> ■ Label size is not specified properly. ■ Sensor sensitivity is not set properly. ■ The media sensor is covered with dust. 	<ul style="list-style-type: none"> ■ Check if label size is setup correctly. ■ Calibrate the sensor by Auto Gap or Manual Gap options. ■ Clear the GAP/Black mark sensor by blower.
RTC time is incorrect when reboot the printer	<ul style="list-style-type: none"> ■ The battery has run down. 	<ul style="list-style-type: none"> ■ Check if there is a battery on the main board.
LCD panel is dark and keys are not working	<ul style="list-style-type: none"> ■ The cable between main PCB and LCD panel is loose. 	<ul style="list-style-type: none"> ■ Check if the cable between main PCB and LCD is secured or not.

6.2 RFID Errors Message

The RFID encoder can detect a number of errors. When one of these errors occurs, the RFID encoder alerts the printer to perform the currently selected error action and display the appropriate error message on the control panel's LCD.

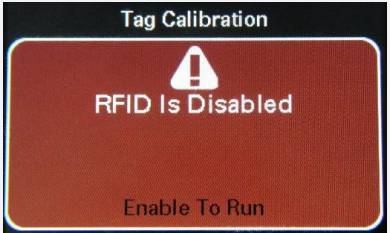
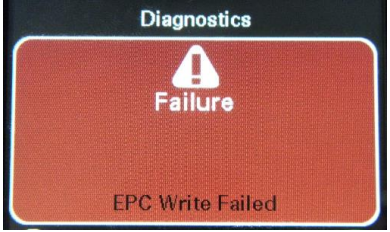
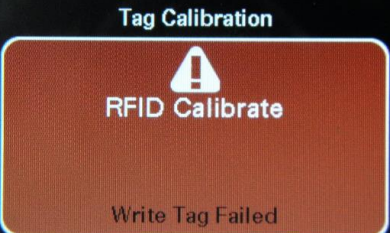
Error Message	Possible Cause	Recovery Procedure
	<ul style="list-style-type: none"> RFID is disabled. 	<ul style="list-style-type: none"> Please go to RFID > Control > RFID Active to enable the RFID.
	<ul style="list-style-type: none"> The EPC tag write failed via Diagnostics > Write EPC with 1s or Write EPC with 2s. 	<ul style="list-style-type: none"> The label could be misaligned. Perform the Sensor > Auto Calibration procedure to ensure the label is at top-of-form. Perform the FRID > Control > Tag Calibration > RFID Calibrate. Make sure the media are smart labels with RFID tags located in the correct position. The RFID tag could be defective. Try another tag. Make sure the application does not send too few or too many digits to the RFID tag.
	<ul style="list-style-type: none"> Tag calibration has failed. 	<ul style="list-style-type: none"> The label could be misaligned. Perform the Sensor > Auto Calibration procedure to ensure the label is at top-of-form. Make sure the media are smart labels with RFID tags located in the correct position. The RFID tag could be defective. Try another tag.

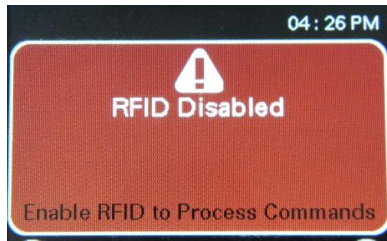

- The RFID command is sent to the printer, but RFID is disabled.
- Please go to RFID > Control > RFID Active to enable the RFID.
- Then process RFID commands.



- When the "Non- RFID warning" option is "ON" (RFID > Control > Non- RFID Warning), the printer will display this warning message once the printer has obtained the non-RFID data.
- N/A

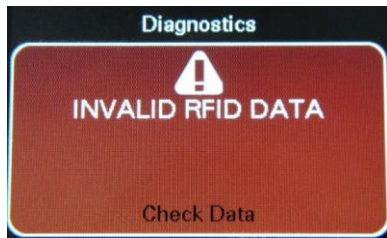

- The tag data sent does not match the settings.
- Please check the tag data of the RFID commands.

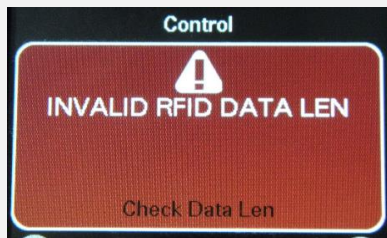

- The tag length size (the size parameter of RFID command) sent does not match the setting.
- Please check the data length size of the RFID commands.



- The tag cannot be written.

- The label could be misaligned. Perform the Sensor > Auto Calibration procedure to ensure the label is at top-of-form.
- Perform the FRID > Control > Tag Calibration > RFID Calibrate.
- Make sure the media are smart labels with RFID tags located in the correct position.
- The RFID tag could be defective. Try another tag.
- Make sure the application does not send too few or too many digits to the RFID tag.
- Check RFID commands are correct.



- The tag cannot be read.

- Make sure the media are smart labels with RFID tags located in the correct position.
- The RFID tag could be defective. Try another tag.

7. RFID Setting Commands

Incorporate RFID commands into new or existing printer programs.

Supported device: Alpha-40L(R) series

IMPORTANT:

With all examples make sure the label length matches the physical length of the installed media.

7.1 RFID ON/OFF

Description

This command is used to enable/disable the RFID encoder module.

Syntax

RFID ON/OFF

<u>Parameter</u>	<u>Description</u>
ON	Enable the RFID encoder module
OFF	Disable the RFID encoder module

Sample Code

Example

```
RFID ON
```

7.2 RFID ERROR

Description

If an error persists after the specified number of labels are tried, perform this error handling action.

Syntax

RFID ERROR OFF/STOP/OVERSTRIKE

<u>Parameter</u>	<u>Description</u>
OFF	No specific action is taken when a tag fails to be programmed.
STOP	Place printer in Pause mode. The label is discarded and reprinting of the label (if desired) must be initiated from the host. When the error is cleared, the label with the failed tag moves forward until the next label is in position to be printed.
OVERSTRIKE	Each failed label prints with the Overstrike pattern and the form retries on a new label until the Label Retry count is exhausted.

Sample Code

Example

RFID ERROR OVERSTRIKE

7.3 RFID RETRY

Description

This command is used to set the number of label retries that the RFID encoder will attempt before declaring a fault.

Syntax

RFID RETRY

<u>Parameter</u>	<u>Description</u>
#	Number of retries (1 ~ 10)

Sample Code

<u>Example</u>
RFID RETRY 2

7.4 RFID RETRYERROR ON/OFF

Description

This command is used to set if errors are declared when the Label Retry count is exceeded.

Syntax

RFID RETRYERROR ON/OFF

<u>Parameter</u>	<u>Description</u>
ON	Enable the RFID retry error function
OFF	Disable the RFID retry error function

Sample Code

Example

```
RFID RETRYERROR OFF
```

7.5 RFID POSITION

Description

This command is used to set the how far the RFID tag encoding position of the currently installed tag should be offset from Top of Form. Normally, this value is set automatically by the RFID calibration process and should not be changed.

Syntax

RFID POSITION

<u>Parameter</u>	<u>Description</u>
#	Position of the antenna (0 ~ 1218 dot)

Sample Code

<u>Example</u>
<code>RFID POSITION 60</code>

7.6 RFID POWER

Description

This command is used to set the for optimal tag encoding. Sets the read/write power level to be used in the RFID encoder. Normally, this value is set automatically by the RFID calibration process and should not be changed.

Syntax

RFID POWER read,write

<u>Parameter</u>	<u>Description</u>
Read	Custom tag read power level setting. (1~27)
Write	Custom tag write power level setting. (1~27)

Sample Code

Example

```
RFID POWER 12,16
```

7.7 RFID COUNTRESET

Description

This command is used to clear the total/failed tag statistics counters.

Syntax

RFID COUNTERSET

<u>Parameter</u>	<u>Description</u>
N/A	

Sample Code

Example

```
RFID COUNTERSET
```

7.8 RFID READ/WRITE

Description

This command allows you to write or read to an RFID tag.

Syntax

RFID a,b,format,start block,size,memory bank,data

<u>Parameter</u>	<u>Description</u>	
a	WRITE = write to the tag READ = read the tag	
b	WRITE only	lock password 0 = write without lock. 1 to FFFFFFFF in hex = <u>write and lock</u> the data block to prevent it from being overwritten.
	READ only	unlock password 0 = read without unlock. 1 to FFFFFFFF in hex = <u>read and unlock</u> the data block so it can be overwritten later.
format	A letter specifying the representation format of the field data. A = ASCII H = Hex	
start block	Specifies the number of blocks to read. This option is valid only for the read operation. (0 to FFFF in hex)	
size	Write/Read data size from 1 to n in decimal number.	
	Note: <ul style="list-style-type: none"> - When using WRITE, if the "size" is larger than the "data", it will be padded with 0 in front of the data to read. - When using READ, if the "size" is larger than the WRITE "data", it will be padded with 0 in back of the data to read. - Refer to the example 3 of sample code. 	

memory bank

- EPC - EPC 12 bytes data area
- TID - Tag identification 8 bytes area (currently not applicable for RFID WRITE)
- USR - User 32 bytes area
- ACS - 4 bytes access code area
- KIL - 4 bytes kill code area
- PC - 2 bytes PC code area (Gen 2 tags only)

data

WRITE = content of data string
READ = [prompt of data]

Note:

- RFID WRITE supported "string" or basic variable (e.g. VAR\$)
- [] = Optional parameter

Sample Code

Example 1

This programming example writes a data into an RFID tag and reads the written data with a prompt.

```
CLS
RFID WRITE,0,H,0,12,EPC,"123456789012"
RFID READ,0,H,0,12,EPC,"Read Data: "
PRINT 1
```

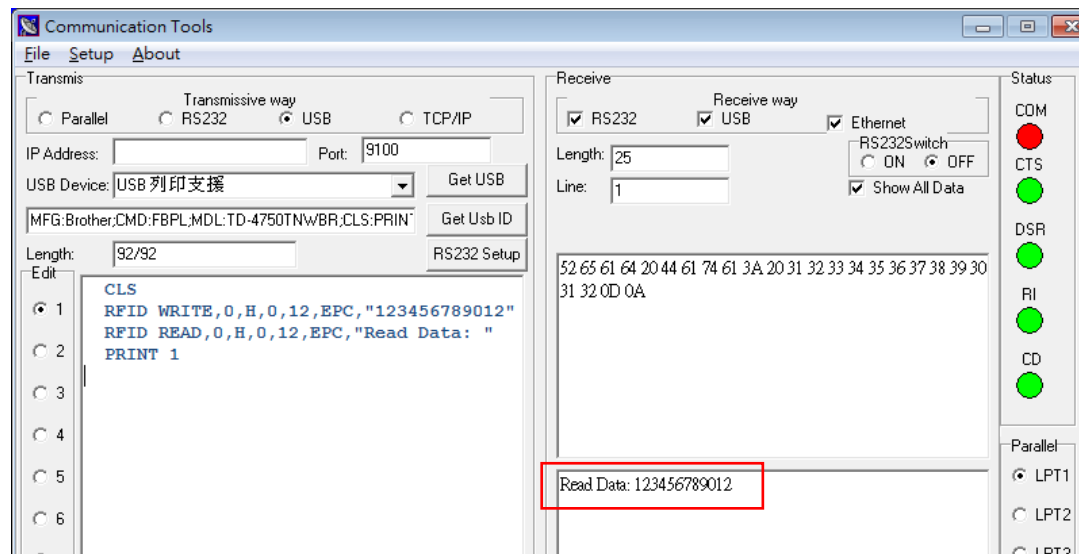

Example 2

This programming example writes a data with lock password into an RFID tag and reads the written data with a prompt.

```
CLS  
RFID WRITE,1234,H,0,8,EPC,"20191008"  
RFID READ,0,H,0,8,EPC,"Date: "  
PRINT 1
```

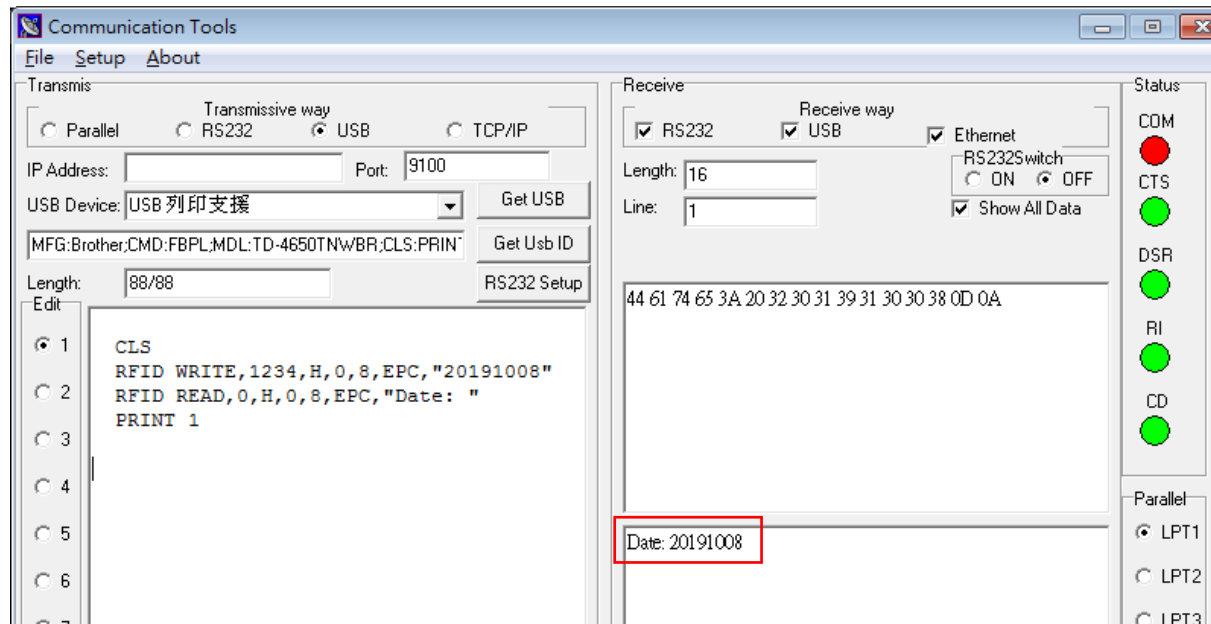

For this locked RFID tag, it cannot be overwritten data without using RFID READ unlock password command. If you re-send the RFID WRITE command, the printer LCD will be shown as below,

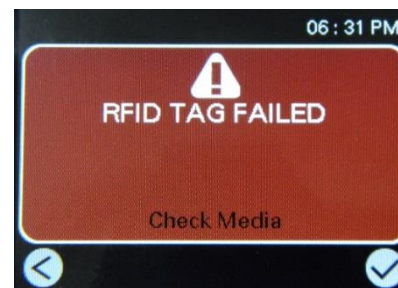

If you need to overwrite this locked tag, please use RFID READ unlock command as following programming example, to unlock password for the RFID tag so it can be overwritten later.

```
CLS
RFID READ,1234,H,0,8,EPC,"Date: "
PRINT 1
```

```
CLS
RFID WRITE,0,H,0,12,EPC,"123456789012"
RFID READ,0,H,0,12,EPC,"Read Data: "
PRINT 1
```

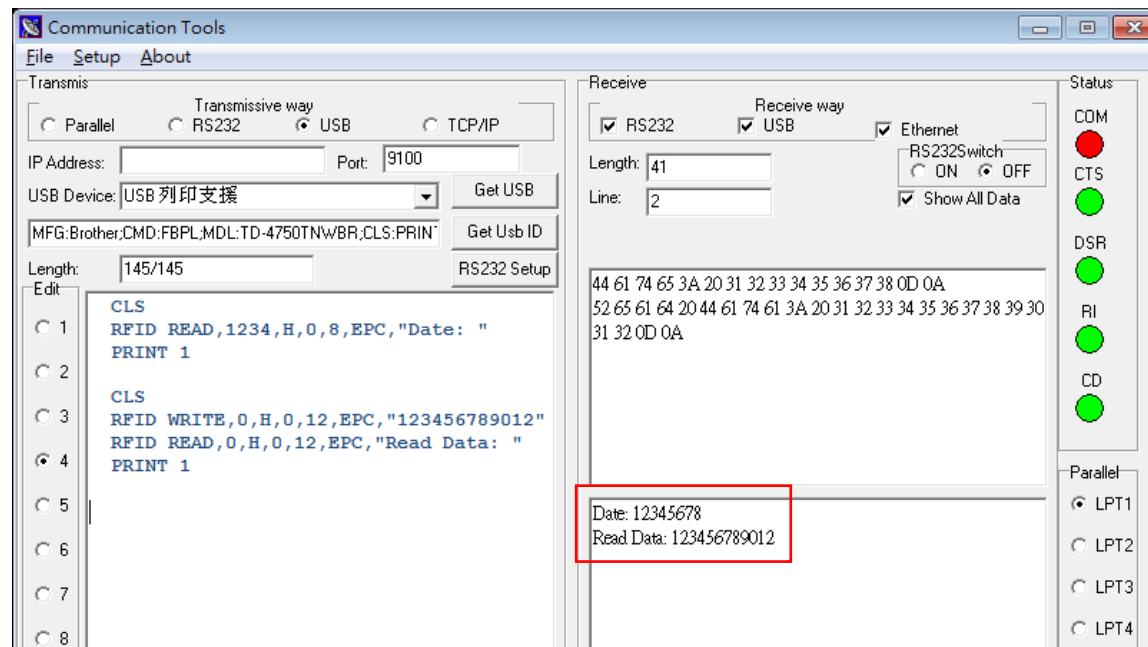

Example 3

When using WRITE, if the "size" is larger than the "data", it will be padded with 0 in front of the data to read. When using READ, if the "size" is larger than the WRITE "data", it will be padded with 0 in back of the data to read.

```
CLS
RFID WRITE,0,H,0,8,EPC,"1234"
RFID READ,0,H,0,8,EPC,"Read Data: "
PRINT 1
```

CLS
 RFID WRITE,0,H,0,8,EPC,"1234"
 RFID READ,0,H,0,12,EPC,"Read Data: "
 PRINT 1

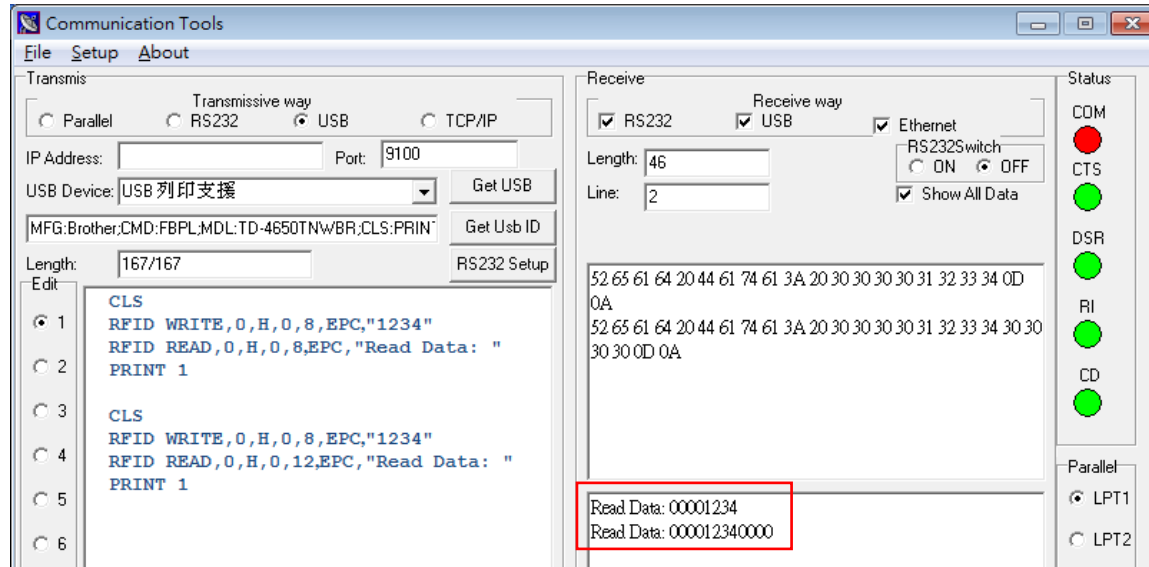

Example 4 (EPC & USR with Lock)

CLS
 RFID WRITE,12345678,H,0,12,EPC,"123456789012"
 RFID WRITE,12345678,H,0,12,USR,"987654321012"
 RFID READ,12345678,H,0,12,EPC,"EPC : "
 RFID READ,12345678,H,0,12,USR,"USR : "
 PRINT 1

Example 5 (EPC & USR & ACS with Lock)

CLS
 RFID WRITE,12345678,H,0,12,EPC,"123456789012"
 RFID WRITE,12345678,H,0,12,USR,"987654321012"
 RFID WRITE,12345678,H,0,8,ACS,"12345678"
 RFID READ,12345678,H,0,8,ACS,"ACS : "
 RFID READ,12345678,H,0,12,EPC,"EPC : "

```
RFID READ,12345678,H,0,12,USR,"USR : "  
PRINT 1
```

Example 6 (EPC & USR & ACS & KIL with Lock)

```
CLS  
RFID WRITE,12345678,H,0,12,EPC,"123456789012"  
RFID WRITE,12345678,H,0,12,USR,"987654321012"  
RFID WRITE,12345678,H,0,8,ACS,"12345678"  
RFID WRITE,12345678,H,0,8,KIL,"12345678"  
RFID READ,12345678,H,0,8,ACS,"ACS : "  
RFID READ,12345678,H,0,8,KIL,"KIL : "  
RFID READ,12345678,H,0,12,EPC,"EPC : "  
RFID READ,12345678,H,0,12,USR,"USR : "  
PRINT 1
```

Example 7 (PC+EPC)

```
CLS  
RFID WRITE,0,H,0,4,PC,"3400"  
RFID WRITE,0,H,0,24,EPC,"123456789012345678901234"  
RFID READ,0,H,0,24,EPC,"EPC: "  
RFID READ,0,H,0,4,PC,"PC: "  
PRINT 1
```

8. Maintenance

This session presents the clean tools and methods to maintain the printer.

For Cleaning

Depending on the media used, the printer may accumulate residues (media dust, adhesives, etc.) as a by-product of normal printing. To maintain the best printing quality, you should remove these residues by cleaning the printer periodically. Regularly clean the print head and supply sensors once change a new media to keep the printer at the optimized performance and extend printer life.

For Disinfecting

Sanitize your printer to protect yourself and others and can help prevent the spread of viruses.

Important

- Set the printer power switch to O (Off) prior to performing any cleaning or disinfecting tasks. Leave the power cord connected to keep the printer grounded and to reduce the risk of electrostatic damage.
- Do not wear rings or other metallic objects while cleaning any interior area of the printer.
- Use only the cleaning agents recommended in this document. Use of other agents may damage the printer and void its warranty.
- Do not spray or drip liquid cleaning solutions directly into the printer. Apply the solution on a clean lint-free cloth and then apply the dampened cloth to the printer.
- Do not use canned air in the interior of the printer as it can blow dust and debris onto sensors and other critical components.
- Only use a vacuum cleaner with a nozzle and hose that are conductive and grounded to drain off static build up.
- All reference in these procedures for use of isopropyl alcohol requires that a 99% or greater isopropyl alcohol content be used to reduce the risk of moisture corrosion to the printhead.
- Do not touch printhead by hand. If you touch it careless, please use 99% Isopropyl alcohol to clean it.

- Always taking personal precaution when using any cleaning agent.

Cleaning Tools

- Cotton swab
- Lint-free cloth
- Brush with soft non-metallic bristles
- Vacuum cleaner
- 75% Ethanol (for disinfecting)
- 99% Isopropyl alcohol (for printhead and platen roller cleaning)
- Genuine printhead cleaning pen
- Mild detergent (without chlorine)

Cleaning Process:

Printer Part	Method	Interval
Print Head	<ol style="list-style-type: none"> I. Always turn off the printer before cleaning the printhead. II. Allow the printhead to cool for at least one minute. III. Use a cotton swab and 99% Isopropyl Alcohol or genuine print head cleaning pen to clean the print head surface. 	Clean the print head when changing a new label roll.
Platen Roller	<ol style="list-style-type: none"> I. Turn off the printer. II. Rotate the platen roller and wipe it thoroughly with the lint-free 99% Isopropyl Alcohol. 	Clean the platen roller when changing a new label roll
Sensor	Use brush with soft non-metallic bristles or a vacuum cleaner, to remove paper dust. Clean upper and lower media sensors to ensure reliable Top of Form and Paper Out sensing.	Monthly
Exterior	Clean the exterior surfaces with a clean, lint-free cloth (water-dampened cloth). If necessary, use a mild detergent or desktop cleaning solution then use the 75% Ethanol to wipe it.	As needed
Interior	Clean the interior of the printer by removing any dirt and lint with a vacuum cleaner, as described above, or use a brush with soft non-metallic bristles then use the 75% Ethanol to wipe it.	As needed

9. Agency Compliance and Approvals



EN 55032, Class B

EN 55024

EN 55035

EN 62368-1

FCC part 15B, Class B

ICES-003, Class B

This equipment has been tested and found to comply with the limits for a Class B digital device, pursuant to part 15 of the FCC Rules. These limits are designed to provide reasonable protection against harmful interference in a residential installation. This equipment generates, uses and can radiate radio frequency energy and, if not installed and used in accordance with the instructions, may cause harmful interference to radio communications. However, there is no guarantee that interference will not occur in a particular installation. If this equipment does cause harmful interference to radio or television reception, which can be determined by turning the equipment off and on, the user is encouraged to try to correct the interference by one or more of the following measures:



- Reorient or relocate the receiving antenna.
- Increase the separation between the equipment and receiver.
- Connect the equipment into an outlet on a circuit different from that to which the receiver is connected.
- Consult the dealer or an experienced radio/ TV technician for help.

This device complies with Part 15 of the FCC Rules. Operation is subject to the following two conditions: (1) This device may cause harmful interference, and (2) this device must accept any interference received, including interference that may cause undesired operation.

This Class B digital apparatus complies with Canadian ICES-003

Cet appareil numérique de la classe B est conforme à la norme NMB-003 du Canada



AS/NZS CISPR 32, Class B



GB 4943.1
GB/T9254
GB 17625.1



IS 13252(Part 1)/
IEC 60950-1



TP TC 004
TP TC 020

Important safety instructions:

1. Read all of these instructions and keep them for later use.
2. Follow all warnings and instructions on the product.
3. Disconnect the power plug from the AC outlet before cleaning or if fault happened.
Do not use liquid or aerosol cleaners. Using a damp cloth is suitable for cleaning.
4. The mains socket shall be installed near the equipment and easily accessible.
5. The unit must be protected against moisture.
6. Ensure the stability when installing the device, Tipping or dropping could cause damage.
7. Make sure to follow the correct power rating and power type indicated on marking label provided by manufacture.
8. Please refer to user manual for maximum operation ambient temperature.

**WARNING:**

Hazardous moving parts, keep fingers and other body parts away.

CAUTION:

Risk of explosion if battery is replaced by an incorrect type.

Dispose of used batteries according to the Instructions as below.

1. DO NOT throw the battery in fire.
2. DO NOT short circuit the contacts.
3. DO NOT disassemble the battery.
4. DO NOT throw the battery in municipal waste.
5. The symbol of the crossed out wheeled bin indicates that the battery should not be placed in municipal waste.

电池安全警告：

- ⊙ 勿将电池扔于火中。
- ⊙ 勿将电池接点短路。
- ⊙ 不可拆解电池。
- ⊙ 不乱将电池当成一般废弃物处理。
- ⊙ 打叉的垃圾桶符号表示电池不应该被放置到一般废弃堆中。

注意:

- ⊙ 更换不正确型号类型的电池, 将产生爆炸危险。
- ⊙ 请根据使用说明处理用过的电池。

鋰電安全使用指南:

注意：電池若未正確更換，可能會爆炸。請用原廠建議之同款或同等級的電池來更換。請依原廠指示處理廢棄電池。



CAUTION:

The printhead may be hot and could cause severe burns. Allow the printhead to cool.

CAUTION:

Any changes or modifications not expressly approved by the grantee of this device could void the user's authority to operate the equipment.

CE Statement:

This equipment complies with EU radiation exposure limits set forth for an uncontrolled environment. This equipment should be installed and operated with minimum distance 20 cm between the radiator & your body.

All operational modes:

2.4GHz: 802.11b, 802.11g, 802.11n (HT20), 802.11n (HT40)

5GHz: 802.11a,

The frequency, mode and the maximum transmitted power in EU are listed below:

2400 MHz – 2483.5 MHz: 19.88 dBm (EIRP)

5150 MHz – 5250 MHz: 17.51 dBm (EIRP)

5150-5350MHz for Only indoor use

5470-5725MHz for indoor/outdoor use

Restrictions In AZE

National restrictions information is provided below

Frequency Band	Country	Remark
5150-5350MHz	Azerbaijan	No license needed if used indoor and power not exceeding 30mW
5470-5725MHz		

Hereby, TSC Auto ID Technology Co., Ltd. declares that the radio equipment type [Wi-Fi] IEEE 802.11 a/b/g/n is in compliance with Directive 2014/53/EU

The full text of the EU declaration of conformity is available at the following internet address: [http:// www.tscprinters.com](http://www.tscprinters.com)

RF exposure warning (Wi-Fi)

This equipment must be installed and operated in accordance with provided instructions and must not be co-located or operating in conjunction with any other antenna or transmitter. End-users and installers must be providing with antenna installation instructions and transmitter operating conditions for satisfying RF exposure compliance.

SAR Value: 0.736 W/kg

RF exposure warning (For Bluetooth)

The equipment complies with FCC RF exposure limits set forth for an uncontrolled environment.

The equipment must not be co-located or operating in conjunction with any other antenna or transmitter.

Canada, Industry Canada (IC) Notices

This Class B digital apparatus complies with Canadian ICES-003 and RSS-210.

Operation is subject to the following two conditions: (1) this device may not cause interference, and (2) this device must accept any interference, including interference that may cause undesired operation of the device.

Radio Frequency (RF) Exposure Information

The radiated output power of the Wireless Device is below the Industry Canada (IC) radio frequency exposure limits. The Wireless Device should be used in such a manner such that the potential for human contact during normal operation is minimized.

This device has been evaluated for and shown compliant with the IC Specific Absorption Rate (“SAR”) limits when installed in specific host products operated in portable exposure conditions. **(For Wi-Fi)**

This device has also been evaluated and shown compliant with the IC RF Exposure limits under portable exposure conditions. (Antennas are less than 20 cm of a person's body). **(For Bluetooth)**

Canada, avis de l'Industry Canada (IC)

Cet appareil numérique de classe B est conforme aux normes canadiennes ICES-003 et RSS-210.

Son fonctionnement est soumis aux deux conditions suivantes : (1) cet appareil ne doit pas causer d'interférence et (2) cet appareil doit accepter toute interférence, notamment les interférences qui peuvent affecter son fonctionnement.

Informations concernant l'exposition aux fréquences radio (RF)

La puissance de sortie émise par l'appareil sans fil est inférieure à la limite d'exposition aux fréquences radio de l'Industry Canada (IC). Utilisez l'appareil sans fil de façon à minimiser les contacts humains lors du fonctionnement normal.

Ce périphérique a été évalué et démontré conforme aux limites SAR (Specific Absorption Rate – Taux d'absorption spécifique) par l'IC lorsqu'il est connecté à des dispositifs hôtes spécifiques opérant dans des conditions d'utilisation mobile. **(Pour le Wi-Fi)**

Ce périphérique a également été évalué et démontré conforme aux limites d'exposition radio-fréquence par l'IC pour des utilisations par des opérateurs mobiles (les antennes sont à moins de 20 cm du corps d'une personne). **(Pour le Bluetooth)**

NCC 警語:

經型式認證合格之低功率射頻電機，非經許可，公司、商號或使用者均不得擅自變更頻率、加大功率或變更原設計之特性及功能。(即

低功率電波輻射性電機管理辦法第十二條)

低功率射頻電機之使用不得影響飛航安全及干擾合法通信；經發現有干擾現象時，應立即停用，並改善至無干擾時方得繼續使用。

前項合法通信，指依電信法規定作業之無線電通信。低功率射頻電機須忍受合法通信或工業、科學及醫療用電波輻射性電機設備之干

擾。(即低功率電波輻射性電機管理辦法第十四條)

單元 Unit	限用物質及其化學符號 Restricted substances and its chemical symbols					
	鉛 Lead (Pb)	汞 Mercury (Hg)	鎘 Cadmium (Cd)	六價鉻 Hexavalent chromium (Cr+6)	多溴聯苯 Polybrominated biphenyls (PBB)	多溴二苯醚 Polybrominated diphenyl ethers (PBDE)
內外塑膠件	○	○	○	○	○	○
內外鐵件	-	○	○	○	○	○
滾輪	○	○	○	○	○	○
銘版	○	○	○	○	○	○
電路板	-	○	○	○	○	○
晶片電阻	-	○	○	○	○	○
積層陶瓷表面黏著電容	○	○	○	○	○	○
集成電路-IC	-	○	○	○	○	○
電源供應器	○	○	○	○	○	○
印字頭	-	○	○	○	○	○
馬達	-	○	○	○	○	○
液晶顯示器	-	○	○	○	○	○
插座	-	○	○	○	○	○
線材	-	○	○	○	○	○

備考 1. “超出 0.1 wt %” 及 “超出 0.01 wt %” 係指限用物質之百分比含量超出百分比含量基準值。

Note 1: “Exceeding 0.1 wt %” and “exceeding 0.01 wt %” indicate that the percentage content of the restricted substance exceeds the reference percentage value of presence condition.

備考 2. “○” 係指該項限用物質之百分比含量未超出百分比含量基準值。

Note 2: “○” indicates that the percentage content of the restricted substance does not exceed the percentage of reference value of presence.

備考 3. “-” 係指該項限用物質為排除項目。

Note 3: The “-” indicates that the restricted substance corresponds to the exemption.

10. Revise History

Date	Content	Editor
2022/4/21	■ The printer's weight is changed from 985g to 1025g.	Camille
2022/5/18	■ Add the RFID setting commands section	Camille
2022/5/25	■ Update the ch.2.1 to add the media core adaptor	Camille

TSC **PRINTRONIX[®]**
AUTO ID